

SMART PREPAID ENERGY METERDr. I.Sataya narayana , Dr.S.Suresh², Madhuri³, P. Shiva Lekhitha ⁴, K.Sai Harshitha ⁵, M. Shiva Kumar ⁶¹Principal and Professor, Dept of Mechanical, Sri Indu Institute of Engineering & Technology, Hyderabad.²Professor, Dept. of ECE, Sri Indu Institute of Engineering & Technology, Hyderabad.³⁻⁶Student, Dept. of ECE, Sri Indu Institute of Engineering & Technology, Hyderabad.**ABSTRACT:**

The project aims at developing a system which helps in monitoring the readings from an energy meter and controlling the switching of energy meter. This system also has tamper switch, which helps in illegal removing of energy meter cabinet[3-9] and alerts the authorities in the form of text message. This also sends data to webpage in real - time with tamper alert status too. The controlling device is microcontroller. IOT modem, Relay, LCD, tamper switch and energy meter[4] are interfaced to the microcontroller. The microcontroller is programmed such that it sends the energy readings to the authorities by sending simple SMS to the system. It helps controlling the energy meter along with tampering proof facility. The readings are displayed on LCD. The microcontroller is loaded with intelligent program written using Embedded 'C' language. The modules in the project are: IOT modem for establishing communication between system at house and electricity department, Energy meter which continuously gives usage details, LCD to display current reading of meter, Relay to disconnect the power in case of nonpayment of bill.

I. INTRODUCTION

Monitoring and keeping tracking of your electricity consumption for verification is a tedious task today since you need to go to meter reading room and take down readings. Well, it is important to know if you are charged accordingly so the need is quite certain. Well, we automate the system by allowing users to monitor energy meter readings over the internet. Our proposed system uses energy meter with microcontroller system to monitor energy usage using a meter. The meter[3-9] is used to monitor units consumed and transmit the units as well as cost charged over the internet using Wi-Fi connection. This allows user to easily check the energy usage along with the cost charged online using a simple web application. Thus, the energy meter[11] monitoring system allows user to effectively monitor electricity meter readings and check the billing online with ease. An embedded system is a combination of software

and hardware to perform a dedicated task. Some of the main devices used in embedded products are Microprocessors and microcontrollers. Microprocessors are commonly referred to as general purpose processors as they simply accept the inputs, process it and give the output. In contrast, a microcontroller not only accepts the data as inputs but also manipulates it, interfaces the data with various devices, controls the data and thus finally gives the result. The "IOT ENERGY METER MONITORING" using Arduino microcontroller is an exclusive project which is used to designing a completely automated for physically disabled persons not only accepts but manipulates it.

II. LITERATURE SURVEY

In 2010, using Multi - appliance power disaggregation technology implementers implemented the linear detection algorithm to determine which appliances are active in their power contributions. Problems are robust to errors in this database. In 2011, using cloud computing Page of it is critical to the continuing engagement and use of the device to save energy. Residences to determine the feedback provided by real - time energy monitors results in lower residential consumption rates during the 30 days after installation. In 2013, using GREEN technology is the smallest Zigbee - compatible node in existence. This technology will be possible in every place sensing of a different data types, from energy metering to environmental monitoring. [9] In 2014, GSM technology implemented automatic power will be reading. In 2016. Using Wi-Fi technology application can develop for Apple and BlackBerry 10 OS, thus providing multiple platform user's support. In 2017, using IOT technology An IoT device was created for measuring the voltage, current, power and energy of a three - phase four - line power line in a laboratory building. Through a brief review of the published literature and previously done work, we can say that the research has done a severe work on the plc power line communication and Internet of Things (IoT). It is concluded from the ken study of their work that in today's world PLC & IoT based

meter could improve the overall efficiency of the existing or present system and could help in examining the unnecessary losses of power in different areastechnology found the solution for efficiency calculation of individual equipment. In 2012, using three feedback system, monitored the energy in residential Real – Time.

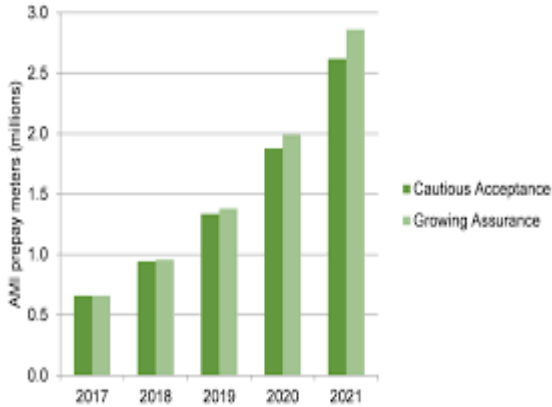

Fig: 1 Smart energy meter utilities

In the proposed method, the consumer can manage their energy consumption by knowing their energy usage time to time. This method not only provides two-way communications between utility and consumer but also provides other functions that are if the consumer fails to pay the electricity bill the energy supply[1] would be cut down from the utility side and once the bill is paid the energy supply is reconnected. Another huge advantage of this system is that it notifies the consumer & utility at the event of the meter tampering. By this information the consumer & utility can control the tampering are reduce energy crises.

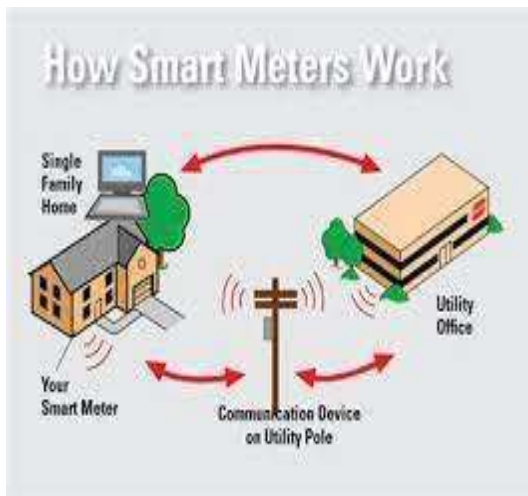

Fig:2 Smart meter work

III.BLOCKDIAGRAM&ITS DESCRIPTION

Power Supply: A regulated power supply converts unregulated AC (Alternating Current) to a constant DC (Direct Current). A regulated power supply is used to ensure that the output remains constant even if the input changes. A regulated DC power supply is also known as a linear power supply; it is an embedded circuit and consists of various blocks. The regulated power supply will accept an AC input and give a constant DC output. The figure below shows the block diagram of a typical regulated DC power supplyWhen ESP8266 hosts the application, and when it is the only application processor in the device, it can boot up directly from an external flash. It has integrated cache to improve the performance of the system in such applications, and to minimize the memory requirements. Alternately, serving as a Wi-Fi adapter, wireless internet access can be added to any microcontroller-based design with simple connectivity through UART interface or the CPU AHB bridge interface.

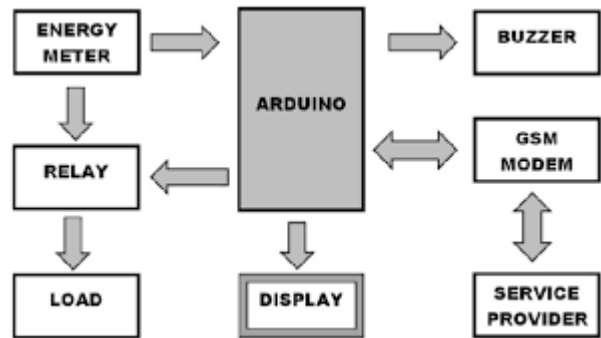

Fig:3 Block diagram

ESP8266 on-board processing and storage capabilities allow it to be integrated with the sensors and other application specific devices through its GPIOs with minimal development upfront and minimal loading during runtime. With its high degree of on-chip integration, which includes the antenna switch balun, power management converters, it requires minimal external circuitry, and the entire solution, including front-end module, is designed to occupy minimal PCB area. Sophisticated system-level features include fast sleep/wake context switching for energyefficient VoIP, adaptive radio biasing for low-power operation, advance signal processing, and spur cancellation and radio co-existence features for common cellular, Bluetooth, DDR, LVDS, LCD interference mitigation.



Fig:4 Arduino uno

GND: Ground Zero reference digital voltage supply.

PORTB (PB7. PB0) PORTB is a port I / O two-way (bidirectional) 8-bit with internal pull-up resistor can be selected. This port output buffers have symmetrical characteristics when used as a source or sink. When used as an input, the pull-pin low externally will emit a current if the pull-up resistor is activated it. PORTB pins will be in the condition of the tri-state when RESET is active, although the clock is not running.

PORTC (PC5. PC0) PORTC is a port I / O two-way (bidirectional) 7-bit with internal pull-up resistor can be selected. This port output buffers have symmetrical characteristics when used as a source or sink. When used as an input, the pull-pin low externally will emit a current if the pull-up resistor is activated it. PORTC pins will be in the condition of the tri-state when RESET is active, although the clock is not running.

PC6/RESET: If RSTDISBL Fuse programmed, PC6 then serves as a pin I / O.

IV.CIRCUIT DIAGRAM & ITS WORKING

WORKING:

The smart meter[11] will monitor by using Arduino nano microcontroller that is ATMEGA328. It maintains 8bit data size, operating range will be 3.3v to 5v. Wi-Fi module (ESP8266) works under six AT commands. Interfacing the Wi-Fi module, liquid crystal display, buzzer, and meter pulse by using C language on Arduino[2] ID1.6.9. LCD is 2line 16 characters, here providing 5v to activate and then it displays the IP address which needs to connect the Wi-Fi module to send the data to processor. The crystal oscillator is maintaining 8bit data size, operating range will be 3.3v to 5v. Wi-Fi module (ESP8266) works under six AT commands. Interfacing the Wi-Fi module, liquid crystal display, buzzer, and meter pulse by using C language on

ArduinoID[10]1.6.9. LCD is 2line 16 characters, here providing 5v to activate and then it **displays the IP** address which needs to connect the Wi-Fi module to send the data to processor. The crystal oscillator is used to convert the digital current signals to alternate current signal which requires maintaining the entire module of energy monitoring system[5]. Load takes 5v power from the power transformer. used to convert the digital current signals to alternate current signal which requires maintaining the entire module of energy monitoring system. Load takes 5v power from the power transformer. Energy meter[3-9] will read the pulse to calculate the amount of consumed power. Here meter[3-9] pulse will be counted for calculating how much power is consumed by the consumer. One example to calculate the amount for consumed power.The smart meter will monitor by using Arduino nano microcontroller[10] that is ATMEGA328. It maintains 8bit data size, operating range will be 3.3v to 5v. Wi-Fi module (ESP8266) works under six AT commands. Interfacing the Wi-Fi module, liquid crystal display, buzzer, and meter pulse by using C language on Arduino ID1.6.9. LCD is 2line 16 characters, here providing 5v to activate and then it displays the IP address which needs to connect the Wi-Fi module to send the data to processor.

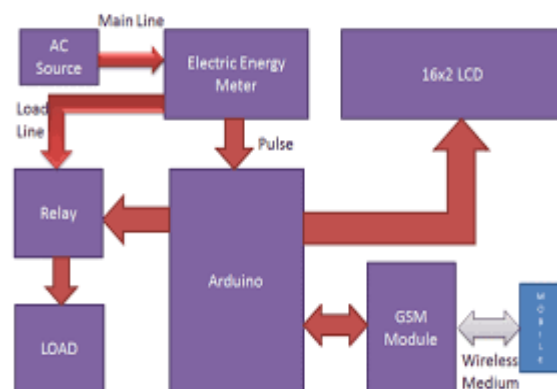

Fig:5 Flow chart

Working steps

- 1.Download and install Arduino nano[2] (Atmega328).
2. Compile the code. It generates hex file.
3. Burn the hex file in Atmega328 using an external burner.
4. Make power supply ON. Wi-Fi module activates, IP address will show on LCD.
5. Search same IP address in a server with AT commands and port number. The power supply will be ON.
6. The server starts counting days with power consumption.
7. The calculation will be done.
8. If the bill is paid supply will be given continuously. If not, then disconnect the line. Providing extra 5 days to pay the bill before disconnecting. After two months

buzzer will be ON for alert purpose. 9. Stop and refresh the page. After two months buzzer will be ON. Smart meter will monitor by using Arduino uno microcontroller[10] that is ATMEGA328, it maintains 8bits requires maintaining the entire module of energy monitoring system[11]. Load takes 5v power from the power transformer.

register, input triggering an edge or level CPU interrupt, input triggering a level wakeup interrupt, open-drain or push-pull output driver, or output source from a software register, or a sigma-delta PWM DAC. These pins are multiplexed with other functions such as host interface, UART, SI, Bluetooth coexistence, etc.



Fig:6 Arduino with GSM module

Memory Controller The memory controller contains ROM, and SRAM. It is accessed by the CPU using the bus, bus and AHB interface. Any of these interfaces can request access to the ROM or RAM modules, and the memory controller arbiters serve these 3 interfaces on a first come-first serve basis. AHB and AHB Blocks the AHB blocks performs the function of an arbiter, controls the AHB interfaces from the MAC, SDIO (host) and CPU. Depending on the address, the AHB data requests can go into one of the two slaves: • APB block, or • flash controller (usually for standalone applications). Data requests to the memory controller are usually high-speed requests, and the APB block are usually register access. The APB block acts as a decoder. It is meant only for access to programmable registers within ESP8266's main blocks. Depending on the address, the APB request can go to the radio, SI/SPI, SDIO (host), GPIO, UART, real-time clock (RTC), MAC or digital baseband. Interfaces The ESP8266 contains several analog and digital interfaces described in the following sections. Master SI / SPI Control (Optional) The master serial interface (SI) can operate in two, three or four-wire bus configurations to control the EEPROM or other I2C/SPI devices. Multiple I2C devices with different device addresses are supported by sharing the 2-wire bus.

3.2 General Purpose IO

There are up to 16 GPIO pins. They can be assigned to various functions by the firmware. Each GPIO can be configured with internal pull-up/down, input available for sampling by a software

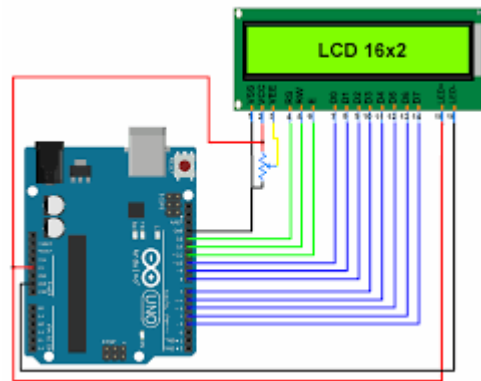

Fig: 7 Arduino with LCD

LCD Background:

One of the most common devices attached to a micro controller is an LCD display. Some of the most common LCDs connected to the many microcontrollers are 16x2 and 20x2 displays. This means 16 characters per line by 2 lines and 20 characters per line by 2 lines, respectively.

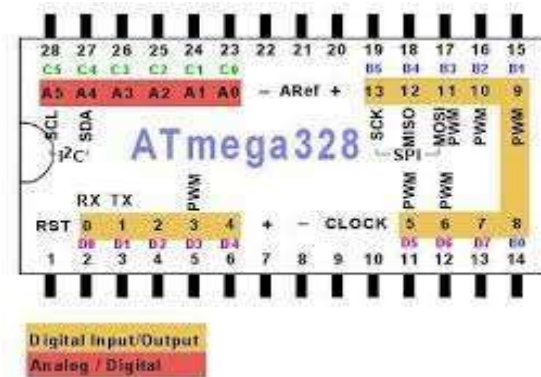

Fig:8 ATMEGA328

Memory: It has 8Kb of Flash program memory (10,000 Write/Erase cycles durability), 512 Bytes of EEPROM (100,000 Write/Erase Cycles). 1Kbyte Internal SRAM I/O Ports: 23 I/ line can be obtained from three ports; namely Port B, Port C and Port D. Interrupts: Two External Interrupt source, located at port D. 19 different interrupt vectors supporting 19 events generated by internal peripherals.

Timer/Counter: Three Internal Timers are available, two 8 bit, one 16 bit, offering various operating modes and supporting internal or external clocking. SPI (Serial Peripheral interface): ATmega8 holds three communication devices integrated. One of them is Serial Peripheral Interface. Four pins are assigned to Atmega8 to implement this scheme of communication. USART: One of the most powerful communication solutions is USART and ATmega8 supports both synchronous and asynchronous data transfer schemes. It has three pins assigned for that. In many projects, this module is extensively used for PC-Micro controller communication. TWI (Two Wire Interface): Another communication device that is present.

V.SOFTWARE DESCRIPTION

This project is implemented using following software: The most common unit of measurement on the electricity meter is the kilowatt hour, which is equal to the amount of energy used by a load of one kilowatt over a period of one hour, or 3,600,000 joules. Some electricity companies use the SI mega joule instead. Demand is normally measured in watts, but averaged over a period, most often a quarter or half hour. Reactive power [5] is measured in "Volt-amperes reactive", (vary) in kilobar-hours. By convention, a "lagging" or inductive load, such as a motor, will have positive reactive power. A "leading", or capacitive load, will have negative reactive power. [4] Volt-amperes measures all power passed through a distribution network, including reactive and actual. This is equal to the product of root-mean-square volts and amperes. Distortion of the electric current by loads is measured in several ways. Power factor is the ratio of resistive (or real power) to volt-amperes. A capacitive load has a leading power factor, and an inductive load has a lagging power factor. A purely resistive load (such as a filament lamp, heater or kettle) exhibits a power factor of 1. Current harmonics are a measure of distortion of the wave form. For example, electronic loads such as computer power supplies draw their current at the voltage peak to fill their internal storage elements. This can lead to a significant voltage drop near the supply voltage peak which shows as a flattening of the voltage waveform. This flattening causes odd harmonics which are not permissible if they exceed specific limits, as they are not only wasteful, but may interfere with the operation of other equipment. Harmonic emissions are mandated by law in EU and other countries to fall within specified limits. Other units of measurements.

```

if((RM >=50)&&(sms_sent==false))
{
  sms.beginSMS(phoneNUM);
  sms.print("SMS from meterEnergy: ");
  sms.print(" \n You reach your limit RM :");
  sms.println(RM);
  sms.endSMS();
  Serial.println("\nCOMPLETE!\n");
  sms_sent = true;
}

```

Fig:9 Code for energy meter

VI.RESULTS

The IOT based smart energy meter monitoring is shown in the fig6. Considering as 5seconds equals to 1day and 1pulses equals 0.1unit power consumption. By taking 5Rs per unit power the bill for two months will be calculated. The same amount will be paid for two months if the user paid the bill the supply will be given continuously after two months. After two months if he doesn't pay bill buzzer will be ON for alert purpose. Until and unless paying bill the supply line will be disconnected. Using Wi-Fi technology is more advantageous for both user side and provider side. There is no need to go at consumer side to disconnect the supply line, using IoT it can be monitored by online only. Energy meter will read the pulse to calculate the amount of consumed power. Here meter pulse will be counted for calculating how much power is consumed by the consumer. One example to calculate the amount for consumed power. The smart meter will monitor by using Arduino nano microcontroller [2] that is ATMEGA328. It maintains 8bit data size, operating range will be 3.3v to 5v. Wi-Fi module (ESP8266) works under six AT commands. Interfacing the Wi-Fi module, liquid crystal display, buzzer, and meter pulse by using C language on Arduino ID1.6.9. LCD is 2line 16 characters, here providing 5v to activate and then it displays the IP address which needs to connect the Wi-Fi module to send the data to processor. The crystal oscillator is used to convert the digital current signals to alternate current signal which requires maintaining the entire module of energy monitoring system. Load takes 5v power from the power transformer. It can transmit the data to the utilities and can receive information from utilities. After two months electricity bill will be paid otherwise supply line will be disconnected through the internet. After two months validity for alert purpose buzzer will be ON. It is easy to know the two

months validity. By making this thing the energy will be monitored[13].



Fig:10 Result of energy meter

VII. CONCLUSION & FUTURE SCOPE

Energy monitoring through the internet[12] is easy. It gives the real power consumption as well as accurate reading. Also, it requires fewer labours and less time to monitor the energy. It can transmit the data to the utilities and can receive information from utilities. After two months electricity bill will be paid otherwise supply line will be disconnected through the internet. After two months validity for alert purpose buzzer will be ON. It is easy to know the two months validity. By making this thing the energy will be monitored. The future scope will be on PC side one server software is required for automatic data collection. In this project, HTML knowledge is taken for demonstration purpose. Energy meter will read the pulse to calculate the amount of consumed power. Here meter pulse will be counted for calculating how much power is consumed by the consumer. One example to calculate the amount for consumed power. Energy meter[11] will read the pulse to calculate the amount of consumed power. Here meter pulse will be counted for calculating how much power is consumed by the consumer. One example to calculate the amount for consumed power. Energy meter will read the pulse to calculate the amount of consumed power. Here meter pulse will be counted for calculating how much power is consumed by the consumer. One example to calculate the amount for consumed power. Energy meter will read the pulse to calculate the amount of consumed power. Here meter pulse will be counted for calculating how much power is consumed by the consumer. One example to calculate the amount for consumed power. Energy meter will read the pulse to calculate the amount of consumed power. Here meter.

VIII. REFERENCES

[1] Sanket Thakare, Akshay Shriyan, Vikas Thale, Prakash Yasarp, Keerthi Unni. “Implementation of an Energy Monitoring and Control Device based on IoT”, 2016 IEEE

[2] Altaf Hamed Shajahan, A. Anand. “Data acquisition and control using Arduino-Android Platform: Smart plug”, 2013 IEEE

[3] Wenjin Li, Xiaoqi Tan, Danny H.K. Tsang. “Smart Home Energy Management Systems Based on Non-Intrusive Load Monitoring”, 2015 IEEE

[4] H G Rodney tan, C H Lee and M H Mok. “Automatic power meter reading system using GSM network”, 2007 IEEE

[5] Sean Dieter Tebje Kelly, Nagender Kumar Suryadevara, and Subhas Chandra Mukhopadhyay “Towards the Implementation of IoT for Environmental Condition Monitoring in Home”2013 IEEE

[6] Alessio Filippi, Ashish Pandharipande, Armand Lelkens, Ronald Rietman, “Multi-appliance power disaggregation: An approach to energy monitoring”, 2010 IEEE International Energy Conference, 2010 IEEE

[7] Laurent Lefevre, Olivier Mornard, Jean-Patrick Gelas, Maxime Morel “Monitoring Energy Consumption in Clouds: The Compatible One experience” 9th IEEE International Conference on Dependable, Autonomic and Secure Computing, 2011 IEEE

[8] Paolo Barsocchi, Erina Ferro, Luigi Fortunati, Fabio Mavilia and Filippo Palumbo “Automatic power reading using GSM network” 2014 IEEE

[9] Yasin Kabir, Yusuf Mohammad Mohsin¹, and Mohammad Monirujaman

[10] Altaf Hamed Shajahan, A. Anand. “Data acquisition and control using Arduino-Android Platform: Smart plug”, 2013 IEEE

[11] Wenjin Li, Xiaoqi Tan, Danny H.K. Tsang. “Smart Home Energy Management Systems Based on Non-Intrusive Load Monitoring”, 2015 IEEE

[12] H G Rodney tan, C H Lee and M H Mok. “Automatic power meter reading system using GSM network”, 2007 IEEE

[13] Sean Dieter Tebje Kelly, Nagender Kumar Suryadevara, and Subhas Chandra Mukhopadhyay “Towards the Implementation of IoT for Environmental Condition Monitoring in Home”2013 IEEE Lelkens, Ronald Rietman, “Multi-appliance power disaggregation: An approach to energy monitoring”, 2010 IEEE International Energy Conference, 2010 IEEE