

## POLLUTION & SAFETY OF VEHICLE USING IOT

Mr. K. Rajender<sup>1</sup>, Dr.D.Lakshmaiah<sup>2</sup>, B. Mohana Naidu<sup>3</sup>, A. Keerthi<sup>4</sup>, Ch. Harshitha<sup>5</sup>

<sup>1</sup>Assistant Professor, Dept. of ECE, Sri Indu Institute of Engineering & Technology, Hyderabad.

<sup>2</sup> Professor & HOD, Dept of ECESri Indu Institute of Engineering & Technology, Hyderabad

<sup>3-5</sup>Student, Dept. of ECE, Sri Indu Institute of Engineering & Technology, Hyderabad

**Abstract:** In this modern era transportation is becoming as one of the important needs of human. Though it has numerous needs, we face lot of problem in it which cost human life. It ensures the driver is not get drunken through the alcohol sensor is deployed to avoid the collision and sends alert message to the official person which give GPS location. This content is based on problems that society is facing in today's world. Pollution continuous to be a significant issue for our environment and many are suffering due to road accidents. It is necessary to monitor air quality for a better future and healthy living for all. We propose an air quality pollution monitoring system that allows us to monitor and check air quality pollution through IoT. This design suggests a precious route for seeing machine emigrations, particularly CO and NH<sub>3</sub> gas emigrations and safety monitoring system.

And also plays important role in preventing drunk and drive accidents. The smoke ratio emitted from the vehicle is monitored by sensors, and the data can be displayed on the phone.

**KEYWORDS:** MQ5 Module, MQ135 Module, MQ3 Module, DHT Module, Node MCU, Motor, Relay, Arduino(UNO), GSM, GPS, Thinkspeak software, NVIDIA.

### I. INTRODUCTION

Vehicle tracking systems are popular among people as a retrieval device and theft prevention. The main benefit of vehicle tracking systems is the security purposes by monitoring the vehicle's location which can be used as a protection approach for vehicles that are stolen by sending its position coordinates to the police center as an alert for the stolen. When a police center receives an alert for stolen vehicles, they can make an action to prevent this theft. Nowadays, it is used either as a replacement or addition for car alarms to protect it from theft or it can be used as a monitoring system to keep track the vehicle at the real time. So, many applications can be used for this purpose to block car's engine or doors as an action to protect the vehicle. Due to the advancement in technology vehicle tracking systems that can even identify and detect vehicle's illegal movements and then attentive the owner about these movements. This gives an advantage over the rest applications and other pieces of technology that can serve for the same purpose. Nowadays, vehicle tracking is one of the most important applications. For example, the maps given to vehicle drivers may play a large role in vehicle tracking and monitoring. The major difficulty is that vehicle owners may not be able to distinguish the vehicle in a place as a result of overlapping maps, which adversely affects the process of tracking and monitoring. It requires some kind of system to detect what distance travelled during a trip to a vehicle. This may be an additional point and help the police in preventing thefts and locating the vehicle by relying on reports from these approved systems and studying and analyzing them to detect stolen vehicles locations. This system is a important device for tracking of vehicles in real time the owner can get to observe or monitor it and today it is really important feature among people having costly cars, used as theft avoidance, recovery of the stolen car and due to some health issues of driver. The collected data can be observed on a digital map by using internet and software There is tremendous demand for object tracking application for the business process. The real-time tracking information could solve many

problems in the world such as valuable things and assets. GPS is the Global Positioning System which provides the location, with this we can get atmospheric conditions. There are several types of GPS tracking system available in the market. Driver fatigue has been the main issue for many problems due to tiredness, tedious road condition, and unfavorable climate situations.

Every year, the National Highway Traffic Safety Administration (NHTSA) and World Health Organization (WHO) have reported that approximately 1.35 million people die due to vehicle crashes across the world. Generally, road accidents mostly occur due to way of driving. These situations occurs due to the driver addiction to alcohol or in drowsiness. The maximum types of lethal accidents are recognized as a severe factor of tiredness of the driver. When drivers fall asleep, then the vehicle will be out of control. There is a need to design smart or intelligent vehicle system through advanced technology. This paper implements a mechanism to alert the driver on the condition of drowsiness or day dreaming and pollution present in air. An message is being transmitted to a destination using IoT module, which relies on wireless transmission.

In current years, drowsy driver detection is the most required process to prevent any road accidents, probably worldwide. The aim of this paper is to construct a smart alert technique for building intelligent vehicles that can automatically informs drowsy driver impairment. But drowsiness is a natural phenomenon in the human body that is produced due to different factors. Hence, it is required to design a robust alert system to avoid the cause of the vehicle accidents and monitoring pollutions emitted by the vehicles, in this proposed paper. When the driver's unconsciousness is detected, the IoT module issues a warning message along with the reasons, if any subsystem faults occurred in engine and location information, thereby alerting with the help of a message through IoT technology from the monitoring system.

## II. LITERATURE REVIEW

The cautious drivers are the majority and they are willing to learn and improve their driving control over vehicle in order to make their life safer. From a safety perspective the driver is helped with a system that monitors driver alertness. This will reduce their chance of respective driver's life getting into an accident with 57 percent.

Nowadays, pollution is became one of the major problems in the world. One of the major cause for the pollution is from vehicle emissions. Harmful Gases for the environment that are released directly from the cars and trucks are the primary source of vehicular pollution. Automobiles also pollute the air during the processes of manufacturing, refueling, and from the emissions associated with oil refining. Government of India to regulate the emission of air pollutants from combustion engine equipment, motor vehicle. To control the pollution emitted by vehicles, the amount of air pollution is needed to be calculated, and vehicle causing pollution must be identified. Internet of Things may become helpful in cities for monitoring air pollution from vehicles and the amount of pollution can be gathered and analyzed. This project is designed to operate the system using a sensor network and gather information about pollutant levels discharged by the vehicles. To control the pollutant from the vehicle the Government has introduced a PUC certification. PUC Certification is important for all vehicles in Indian roads. The validity of the certificate is 6 months. After that, we must take a new certificate which is valid for next 6 months.

To overcome this real time problem, our proposed system has an subsystem inside the vehicle that monitors the continuous emission of pollutant. Gas sensors are used to detect and monitors the air pollution level in air. When the concentration level of gas increases, the output voltage from the gas sensor also increases. Various technology uses various type of sensors A solid-state sensor consists of one or more metal oxides from the transition metals, such as tin oxide, aluminum oxide, etc. These metal oxides are prepared and processed into a paste, which is used to form a bead-type sensor. There are various solid-state sensors: solid- electrolyte type,

capacitor and semiconductor sensor.

This proposed system has been developed to work efficiently in real time. In reference a system has been developed in which tags are used. It detects the pollutant level of each vehicle and then the database is used to store the coming information. For further analysis the observation is sent to the internet server. For the air pollution monitoring, wireless sensor networks are best to use for real time condition. In Air Quality Index and algorithm are used in for data Aggregation. In this system, sensors and Arduino has been used to monitor air pollution. This system provides real time information of the contamination of different gas pollutants presents in air. Had made a system for air pollution monitoring. This system is used effectively to perform analysis in Vishakhapatnam. To detect the percentage of pollution an array of sensors is used and conversions of observed concentration to corresponding electrical signal are used for further processing.

To transmit the observed data by the sensors Using Wi-Fi technology has been used. The usage of Wi-Fi has been increased but at the same time the node life time has been affected with increase in power consumption. Same can be employed in any industry. has been used for creation of web portal in which the inputs are provided by the user for controlling the appliances. In Internet of things (IOT) has been used in which large numbers of distinct devices are connected throughout different systems.

### III. EXISTING SYSTEM

Global air pollution is one of the major concerns of our era. One of the major factors of air pollution is harmful pollutant emitted by vehicles. Each and every vehicle emits pollutant of certain standards, but the main problem arises when they exceed the standard norms. The actual cause for the violation of emission levels is the incomplete combustion of fuel inside the engine which is mainly due to the improper maintenance of vehicles. This emission from vehicles cannot be completely avoided, but it can be definitely controlled.

To overcome the problems of existing systems, a system is proposed to monitor emission level of individual vehicles. An IoT kit is prepared using gas sensors, Arduino integrated development environment (IDE), and a Wi-Fi module.

This kit can be physically placed in exhaust system of every vehicle. The gas sensors gather data from exhaust of vehicle and forward the data to the Arduino. The Arduino transmits the data to the cloud via the Wi-Fi module node MCU. A server is also designed which keeps the information about the emission level of every vehicle so that RTO can access relevant data from the server. The controller continuously monitors the emission of the vehicles and if its emission exceeds standard norms a notification is generated and is interpreted by RTO. Hence using this pollution control circuit emission of individual vehicles can be monitored which helps in reducing the pollution level.

### IV. PROPOSED SYSTEM

This kit can be physically placed in exhaust system of every vehicle. The gas sensors gather data from exhaust of vehicle and forward the data to the Arduino. The Arduino transmits the data to the cloud via the Wi-Fi module node MCU. A server is also designed which keeps the information about the emission level of every vehicle so that RTO can access relevant data from the server. The controller continuously monitors the emission of the vehicles and if its emission exceeds standard norms a notification is generated and is interpreted by RTO. Hence using this pollution control circuit emission of individual vehicles can be monitored which helps in reducing the pollution level.

A alert technique for generating intelligent vehicles that can automatically avoid drowsy driver impairment. But drowsiness is a natural phenomenon in the human body that causes due to

different factors. Hence, it is required to design a robust alert system to avoid accidents. When the driver's unconsciousness is detected, the IoT module issues a warning message and location information, thereby alerting with the help of message through the monitoring system.

## V. REQUIREMENTS SPECIFICATION

### 1. NVIDIA:

Designed for use in power-limited environments, the Jetson Nano squeezes industry-leading compute capabilities, 64-bit operating capability, and integrated advanced multi-function audio, video and image processing pipelines into a 260-pin SODIMM.

The Maxwell GPU architecture implemented several architectural enhancements designed to extract maximum performance per watt consumed.

Each MPIO can be configured to act as a GPIO or it can be assigned for use by a particular I/O controller. Though each MPIO has up to five functions (GPIO function and up to four SFIO functions), a given MPIO can only act as a single function at a given point in time. The functions for each pin on the Jetson module are fixed to a single SFIO function or as a GPIO. The different MPIO pins share a similar structure, but there are several varieties of such pins. The varieties are designed to minimize the number of on-board components (such as level shifters or pull-up resistors) required in Jetson Nano designs.



Humidity measurement range: 20 - 90%RH. Output digital signals indicating temperature and humidity. Working voltage: DC 5V; PCB size: 2.0 x 2.0 cm. Humidity measurement accuracy:  $\pm 5\%$  RH. Temperature measurement accuracy:  $\pm 2^\circ\text{C}$ .

### 2. MQ-3 Gas Sensor:

Sensitive material of MQ-3 gas sensor is SnO<sub>2</sub>, which with lower conductivity in clean air. When the target alcohol gas exists, The sensor's conductivity is more higher along with the gas concentration rising. Please use simple electro circuit, convert change of conductivity to correspond output signal of gas concentration.

MQ-3 gas sensor has high sensitivity to Alcohol, and has good resistance to disturb of gasoline, smoke and vapor. The sensor could be used to detect alcohol with different concentration, it is with low cost and suitable for different application. Metal oxide sensors are also known as Chemiresistors, the working of the sensing is based on the change of resistance of the sensing material when exposed to alcohol. So, by keeping it in a simple voltage divider network, alcohol concentrations can be detected.

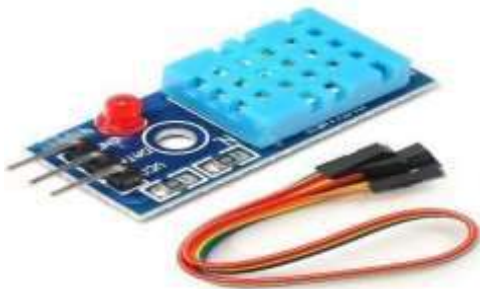

Figure 1: NVIDIA

## 2. DHT11

The digital temperature and humidity sensor DHT11 is a composite sensor that contains a calibrated digital signal output of temperature and humidity. The technology of a dedicated digital modules collection and the temperature and humidity sensing technology are applied to ensure that the product has high reliability and excellent long-term stability.

The sensor includes a resistive sense of wet component and an NTC temperature measurement device, and is connected with a high-performance 8-bit microcontroller. Only three pins are available for use: VCC, GND, and DATA. The communication process begins with the DATA line sending start signals to DHT11, and DHT11 receives the signals and returns an answer signal. Then the host receives the answer signal and begins to receive 40-bit humidity data (8-bit humidity integer + 8-bit humidity decimal + 8-bit temperature integer + 8-bit temperature decimal + 8-bit checksum). Its temperature measuring range is from -40 to +125 degree Celsius with +0.5 degrees accuracy.



**Figure 2: DHT Module**

**Figure 3 : MQ-5 Gas Sensor**

## 3. Node MCU

NodeMCU is an open source IoT platform. It includes firmware which runs on the ESP8266 Wi-Fi SoC from if Systems, and hardware which is based on the ESP- 12 module. The term "NodeMCU" by default refers to the firmware rather than the development kits. The firmware uses the Lua scripting language. It is based on the project, and built on the if Non-OS SDK for ESP8266. It uses many open-source projects, such as lua-cjson and SPIFFS.

The NodeMCU (Node Microcontroller Unit) is an open-source software and hardware development environment built around an inexpensive System-on-a-Chip (SoC) called the ESP8266. The ESP8266, designed and manufactured by if Systems, contains the crucial elements of a computer: CPU, RAM, networking (Wi-Fi), and even a modern operating system and SDK. That makes it an excellent choice for Internet of Things (IoT) projects of all kinds. However, as a chip, the ESP8266 is also hard to access and use. You must solder wires, with the appropriate analog voltage, to its pins for the simplest tasks such as powering it on or sending a keystroke to the "computer" on the chip.

The program it in low-level machine instructions that can be interpreted by the chip hardware. This level of integration is not a problem using the ESP8266 as an embedded controller chip in mass-produced electronics. It is a huge burden for hobbyists, hackers, or students who want to experiment with it in their own IoT projects.

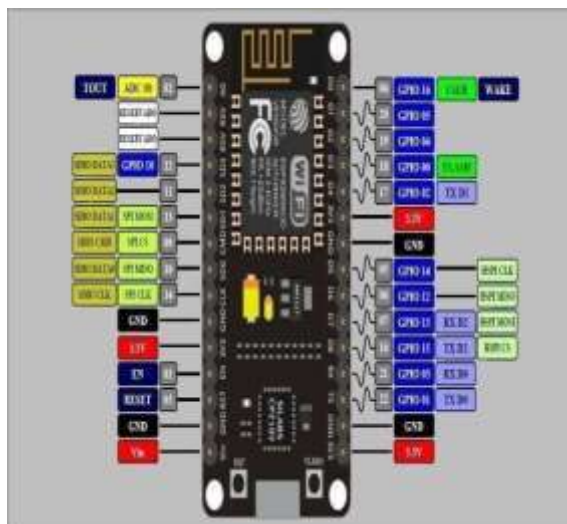

Figure 4 : Node MCU



Figure 5:  
Arduino UNO  
Carrier  
Synchronization:

**Working:**

Satellite navigation is based on a global network of satellites that transmit radio signals in medium earth orbit. Users of satellite navigation are most familiar with the 31 global positioning system (GPS) satellites\*. The United States, who developed and operates GPS, and Russia, who developed a similar system known as glens, have offered free use of their respective systems to the international community. The international civil aviation organization (ICAO), as well as other international user groups, have accepted GPS and glens as the core for an international civil satellite navigation capability known as the global navigation satellite system (GNSS).

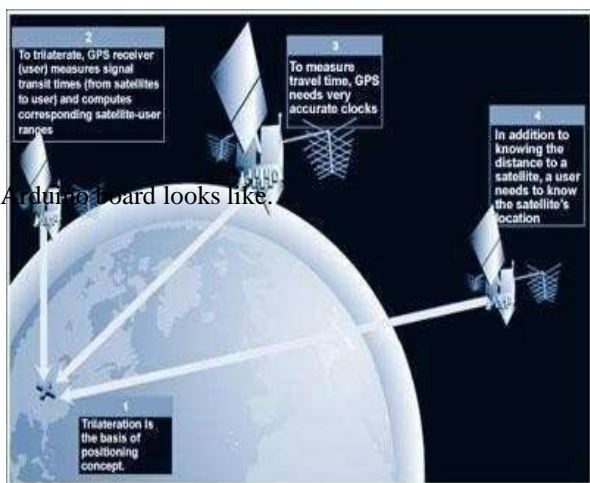

Figure 6 : Satellite Navigation

The carrier tracking function is similar to the processing that occurs in conventional radiocommunications receivers. It enables a receiver to track and process carrier phase information, which is instrumental in demodulating the data message.

In navigation receivers, this carrier information is also useful for several other navigation-related functions that can increase precision or timeliness of the navigation solution, and also to enhance overall receiver tracking performance.

**1. SOFTWARE IMPLEMENTATION :**

ThingSpeak is an open-source software written in Ruby which allows users to communicate with internet enabled devices. It facilitates data access, retrieval and logging of data by providing



an API to both the devices and social network websites. ThingSpeak was originally launched by Bridge in 2010 as a service in support of IoT applications.

ThingSpeak has integrated support from the numerical computing software MATLAB from MathWorks,[4] allowing ThingSpeak users to analyze and visualize uploaded data using MATLAB without requiring the purchase of a MATLAB license from MathWorks.

ThingSpeak is an IoT analytics platform service that allows you to aggregate, visualize, and analyze live data streams in the cloud. You can send data to ThingSpeak from your devices, create instant visualization of live data, and send alerts.

ThingSpeak enables sensors, instruments, and websites to send data to the cloud where it is stored in either a private or a public channel. ThingSpeak stores data in private channels by default, but public channels can be used to share data with others. Once data is in a ThingSpeak channel, you can analyze and visualize it, calculate new data, or interact with social media, web services, and other devices. ThingSpeak provides access to MATLAB to help you make sense of data. You can:

#### 4. Arduino UNO

The Arduino microcontroller open-source single board computer that has gained considerable traction in the hobby and professional market. The Arduino is open-source, which means hardware is reasonably priced and development software is free. This guide is for students in me 2011, or students anywhere who are confronting the Arduino for the first time. For advanced Arduino users, prowl the web; there are lots of resources. This is what the

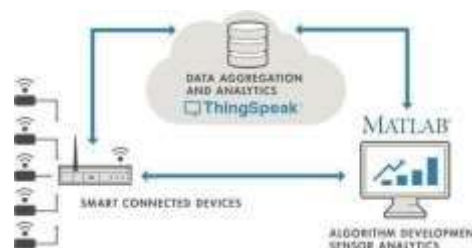

#### 7 : Thinkspeak

- Convert, combine, and calculate new data.
- Schedule calculations to run at certain times.
- Visually understand relationships in data using built-in plotting functions.
- Combine data from multiple channels to build a more sophisticated analysis.
- This library enables an Arduino or other compatible hardware to write or read data to or from ThingSpeak, an open data platform for the Internet of Things with MATLAB analytics and visualization.
- Hardware specific examples are found here. But to give you an idea of usage examples for writing and reading with an ESP8266 are shown below. Complete documentation is also shown below.
- ThingSpeak offers free data storage and analysis of time-stamped numeric or alphanumeric data. Users can access ThingSpeak by and creating a ThingSpeak user account.
- ThingSpeak stores data in channels. Channels support an unlimited number of timestamped observations (think of these as rows in a spreadsheet). Each channel has up to 8 fields (think of these as columns in a spreadsheet). Check out this for an overview.

- Convert, combine, and calculate new data.
- Schedule calculations to run at certain times.
- Visually understand relationships in data using built-in plotting functions.
- Combine data from multiple channels to build a more sophisticated analysis.
- This library enables an Arduino or other compatible hardware to write or read data to or from ThingSpeak, an open data platform for the Internet of Things with MATLAB analytics and visualization.
- Hardware specific examples are found here. But to give you an idea of usage examples for writing and reading with an ESP8266 are shown below. Complete documentation is also shown below.
- ThingSpeak offers free data storage and analysis of time-stamped numeric or alphanumeric data. Users can access ThingSpeak by creating a ThingSpeak user account.
- ThingSpeak stores data in channels. Channels support an unlimited number of timestamped observations (think of these as rows in a spreadsheet). Each channel has up to 8 fields (think of these as columns in a spreadsheet). Check out this for an overview.

Channels may be public, where anyone can see the data, or private, where only the owner and select users can read the data. Each channel has an associated Write API Key that is used to control who can write to a channel. In addition, private channels have one or more Read API Keys to control who can read from private channel

## VII. SIMULATION RESULT

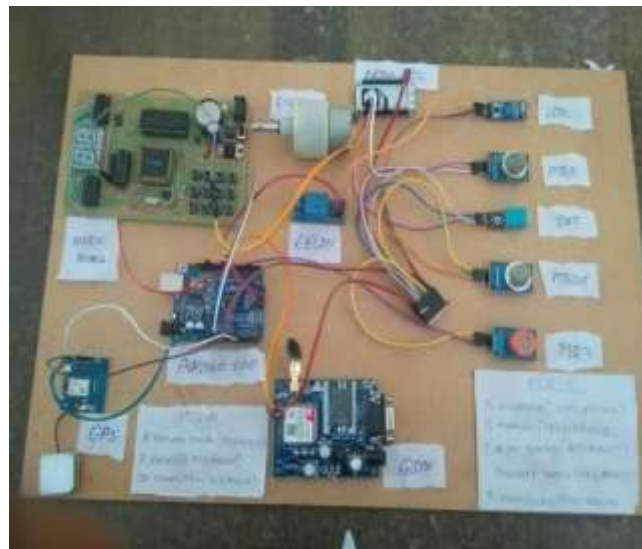

**Figure 8 : Result**

The designed smart intelligent environmental system monitors the adulterants produced by the vehicles and also advise the vehicle possessors to control the pollution. The system also sends the pollutant position data to the garçon for unborn analysis. The air pollution agencies can suitable to dissect the data and also descry the vehicle enrollment figures that causes further pollution in the atmosphere. The advanced system is a low cost, simple to operate and is fluently fitted in many locales. The advanced system provides better delicacy with low cost than the being system.



### VIII. CONCLUSION

The system to monitor various parameters of environment using NVIDIA microcontroller, GSM Technology is proposed to improve quality of air. With the use of technologies like GSM enhances the process of monitoring various aspects of environment such as air quality monitoring issue proposed in this paper. The detection and monitoring of dangerous gases is taken into account in a serious manner and related precautions have been considered here in the form of an alert message and a buzzer so that the necessary action may be taken. It is estimated that this system will have a great acceptance in the market as it is a centralized system for a complete monitoring function. The smart way to monitor the environment and an efficient, low cost embedded system is presented with different models in this paper.

In the proposed architecture function of different modules were discussed. The noise and air pollution monitoring system with Internet of Things concept experimentally tested for monitoring two parameters. This data will be helpful for future analysis and it can be easily shared to other end users. This model can be further expanded to monitor the developing cities and industrial zones for pollution monitoring. To protect the public health from pollution, This model provides an efficient and low cost solution for continuous monitoring of environment.

### IX. REFERENCE

- [1] Aaina Venkateswaran , Harsha Menda P and Prof Priti Badar “ An IoT Based System for Water Quality Monitoring” International Journal of Innovative Research in Computer and Communication Engineering Vol. 5, Issue 4, April 2017
- [2] N Vijaykumar, R Ramyas, “The real time monitoring of water quality in IOT environment”, IEEE sponsored 2nd international conference on innovations in information, embedded and communication systems 2015.
- [3] Nagaraj Pandian M, Ram Prasanth U, Selva Kumar G, Tamil Selvan S, “Automatic irrigation system on sensing soil moisture content”, International journal of Innovative Research in Electrical, Electronics, Instrumentation and Control Engineering, Volume 3, Issue 1, 2015
- [4] Palaghat Yaswanth Sai “An IoT Based Automated Noise and Air Pollution Monitoring System” Vol 6, Issue 3, March 2017.
- [5] Samer Mansour, Nidal Nasser, Lutful Karim, Asmaa, Ali, “Wireless Sensor Network- based Air Quality Monitoring System”, International Conference on Computing, Networking and Communications, Wireless AdHoc and Sensor Networks (IEEE), 2014.
- [6] Riteeka Nayak, Malaya Ranjan Panigrahy, Vivek Kumar Rai and T Appa Rao: IOT based air pollution monitoring system Vol-3, Issue-4, 2017.