

SMART RASPBERRY PI AND NODE MCU-BASED E-AGRICULTURE SYSTEM

Dr.I .Satya narayana, Prof. R.Yadagiri Rao², CH. Manideep Reddy³, D. Gireesh Ratod⁴, D. Sravika⁵,
G. Sandhya⁶.

¹Professor, Dept. of ME, Sri Indu Institute of Engineering & Technology, Hyderabad

²Professor& Head of Dept., Dept. of H&S, Sri Indu Institute of Engineering & Technology.

³⁻⁶Student,Dept. of ECE, Sri Indu Institute of Engineering & Technology, Hyderabad.

ABSTRACT: Agriculture is one of the main factors contributing to the economic growth of many nations. It is also the primary source of livelihood of majority people in the world. The project designed and discussed is a smart farming system that can handle almost all essential facts related to irrigation and crop growth. From the farmer's point of view, smart farming should provide the farmer advantage of dust control and with added value in the form of better decision making or more efficient exploitation operations and management. By referring to this system it can solve problems like monitoring of water, soil degradation, etc. In this paper, by using Pi it can monitor all other applications like GSM, digital sensors, and DC motor with pump

Keywords: IoT, Node MCU, Raspberry Pi, Relay, Sensors.

1.INTRODUCTION:

In India agriculture contributes about 22% of the county's economy. Smart agriculture does not only focus on distance farming but also on yield growth. We are in a situation

where we have limited land to cultivate and unexpected climatic changes which effects the crop growth and yield which is not sufficient for the huge world population. This project aims to crop surveillance and in maintaining factors needed for good crop growth. It helps in getting more yield with fewer resources. The identification of disease was done manually, in all of these techniques the digital domain is widely being used. The use of a digital system gives intuitive judgment. The early judgment of disease makes the farmer avoid losses Agriculture will provide good results in return. In most cases, the disease symptoms are seen in the parts of the leaf, stem, and fruit. In this, we are developing a system that detects the disease present in the plant leaf.

2. Literature survey:

The paper aims at designing a complete device that helps to automate the agricultural field, which reduces the workload on farmers. This proposed system provides an automatic irrigation device and rooftop control system for the farmer on the premise of a Wi-Fi sensor community. They have developed a mobile application. The system deals with real-time observation with efficient use of the cheapest security system. This system

ShodhaSamhita : Journal of Fundamental & Comparative Research

Vol. VIII, No. 1, January - June : 2022

ISSN: 2277-7067

uses Raspberry Pi, sensors, an IP camera,

and their

methodology. The difficulty faced is in the use of a strong security system for both day and night. The challenge faced by them is to turn the traditional method of irrigation into a modern method by introducing the extent of automation to monitor the field. The aim is to make a smart agriculture system by the use of a technique called Precision Agriculture (PA) majorly used in greenhouse farming. The main of the system is to reduce one of the major agriculture problems that are turning the motor on and off. To avoid this wireless monitoring irrigation system is developed.

3. Methodology:

A. Problem Statement:

The major problem that farmers face is the irregular -distribution of water in the field. Crops do not get the required nutrients because of poor soil quality which results in their improper growth.

B. Proposed solution:

We are designing an IoT-based Smart Agricultural Aid System which is based on Raspberry Pi and Node MCU automatically by sensing the essential factors by the sensors. The moisture content and humidity and temperature are measured using the Soil Moisture Sensor and DHT11 Sensor respectively. Node MCU is used to connect all sensors and carries the sensor’s information to the Raspberry Pi.

The camera is used to monitor the crop and for surveillance. Here camera connected Raspberry Pi is used as a server. Relays are used as switches for operating motor and light. Motor runs only when the water content is less than the value of the threshold in the soil. Electronic fencing to avoid animals entering inside an agricultural land. A gassensor is used to detect the concentration of CO2 in the greenhouse. The total information is updated on the web server at a regular interval of time as graphs.

Functional Block Diagram

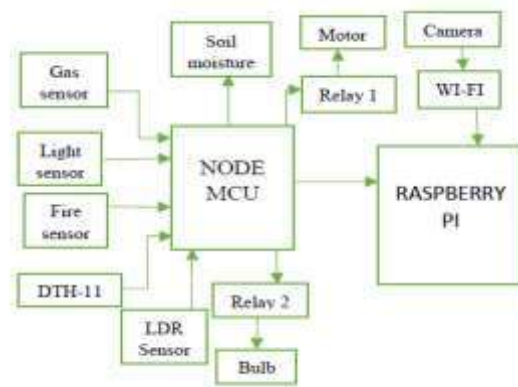

Block Diagram

Initially, all the sensors sense the condition of the humidity, temperature, light, and CO2 concentration in the greenhouse and send it to the Node MCU then the information is sent to the Raspberry Pi. Raspberry Pi then analyses

4. WORKING:

Sensor network nodes are tiny objects which are installed in the different monitoring areas of the wireless sensor networks, to measure various physical data and finish the specified task. Improvement in the growth of various crops depends on various environmental parameters such

as light intensity, soil moisture, relative humidity, soil temperature, usage of fertilizers and pH of the soil, etc.

A. Temperature Sensor:

The temperature sensor used in the project is LM35 which is an IC. It has three terminals and required a Maximum of 5.5V supply. This type of sensor consists of a material that operates according to temperature to vary the resistance. This change of resistance is sensed by the circuit and it calculates the temperature. When the voltage increases then the temperature also rises. It shows temperature ranges from 0- 50 degrees celsius with an accuracy of 0.5 degrees celsius.

B. Soil Moisture Sensor:

The Moisture Sensor detects the moisture of the soil around the sensor, which is ideal for monitoring the plants or the soil moisture. This sensor uses the two probes to pass current through the soil, and then it reads that resistance to get the moisture level. Excess water makes the soil conduct electricity better; while dry soil conducts electricity poorly. The figure shows a typical soil moisture sensor and the output on the LCD from the sensor used in the proposed system

C. Rain Sensor:

The rain sensor detects water that completes the circuits on its sensor boards' printed leads. The sensor board acts as a variable resistor that will change from 100k ohms

when wet to 2M ohms when dry. In short, the wetter the board the more current that will be conducted. To test the Rain Sensor and ensure that it is working correctly connect the VCC to a 5v power source and GND. Try placing a few droplets of water on the Rain sensor detection board and the D0-LED should light up. The code used for the rain sensor maps and reads the analog values given by the Rain Sensor (0-1024).

D. Light Sensor:

There are different types of light sensors available such as photo resistors, photodiodes, photovoltaic cells, phototubes, phototransistors, charge-coupled devices, and so on. But, LDR (Light Dependent Resistor or photo resistor) is used as a light sensor.

Humidity sensor:

The humidity sensor senses the humidity in the soil, it helps in the maintenance of about 45%-90% humidity level for healthy growth of the crop. If the humidity level is below the threshold value the motor is opened.

Gas sensor:

The gas sensor is used to calculate the concentration of the CO₂ gas in the atmosphere. If the CO₂ concentration is less then the rooftop and side walls can be lifted.



Result:

Fig: Circuit Diagram



Fig: Output of temperature sensor on the web

S



Fig: output of humidity sensor on the web



Fig: Output of the gas sensor on the web



Fig: Output of soil moisture sensor on the web



Fig: Output of light sensor on the web

Fig: Output of IR sensor on the web

The values from the sensors are directly sent to the web app through the internet with the help of Node MCU and Raspberry Pi. Hence, by using the thingspeak app, a farmer can get the information about his land and crops directly in the app sitting at any corner. This reduces the tiredness faced by him due to often visiting this farm for observation. The app gives the values in the form of a graph so that the previous values can be easily studied and thus the future values can be predicted. The output from the sensors is given out by the web app.

CONCLUSION

The proposed system provides a simple, cost-effective, eco-friendly, and efficient solution for irrigation. This system can prove to be highly beneficial in many developing nations whose economy is supported by agriculture. It also aims to solve the problem of the energy crisis effectively. This system also eliminates water wastage and reduces human intervention, thereby leading to economic growth,

increased productivity, more people adopting smart farming, and thereby increasing the income of farmers. This system would therefore enable the growth of agriculture to a great extent and attract more people to agriculture.

REFERENCES:

1. "Internet of Things – number of connected devices worldwide 2015-2025". Statista.com.
<https://www.statista.com/statistics/512673/worldwide-internet-of-things-market/>. (Online: June 16th, 2019).
2. "IoT Project List: Database of Enterprise IoT Projects 2018". Statista.com
<https://www.statista.com/topics/4134/smart-agriculture/>. (Online: June 16th, 2019).
3. "MQTT". <http://mqtt.org/>. (Online: June 16th, 2019).
4. "Raspberry Pi" <https://www.raspberrypi.org/> (Online: June 16th, 2019).
5. "Thingspeak services" <https://thingspeak.com/> (Online: June 16th, 2019).
6. "Raspberry Pi Compute Module 3+ (Datasheet)". [Raspberrypi.org](https://www.raspberrypi.org/documentation/)
<https://www.raspberrypi.org/documentation/>