

High performance of Farmer-Friendly Agriculture System base on IoT

Dr K.Srinivasa Reddy¹, Dr.MD Rahaman,² A.Vaani³, Y.Rajani⁴, K.Padma⁵, K.mallaiah⁶, P.Rajini⁷

¹Professor, Department of ECE, Sri Indu Institute of Engineering & Technology, Hyderabad

²Professor, Department of ECE, Sri Indu Institute of Engineering & Technology, Hyderabad

^{3,4,5,6}Assistant Professor, Department of ECE, Sri Indu Institute of Engineering & Technology, Hyderabad

⁷IVth Btech Student, Department of ECE, Sri Indu Institute of Engineering & Technology, Hyderabad

Abstract— The agriculture is one of the most fundamental resource of food production and also plays a vital role in keeping the economy running of every nation by contributing to the Gross Domestic Production. But there are several issues related to traditional methods of agriculture such as excessive wastage of water during irrigation of field, dependency on non-renewable power source, time, money, human resource etc. Since every activity now a days becoming smart it needs to smartly develop agriculture sector for growth of country. This paper aims at developing the Smart Irrigation System Using IoT Technology with an objective of automating the total irrigation system which provide adequate water required by crop by monitoring the moisture of soil and climate condition in order to prevent the wastage of water resource. It will also have many advantages for farmers. The irrigation at remote location from home will become easy and more comfortable. In addition, it will not only protect the farmer from scorching heat & severe cold but also save their time for to and fro journey to the field.

Keywords: *IoT, Automation, Soil Moisture Sensor, Rain Sensor, 328P microcontroller, Wi-Fi, HTTP protocol, API.*

I. INTRODUCTION

According to the UN projections, world population will rise from 6.8 billion today to 9.1 billion in 2050 that signifies food production has to be raised to feed the one third more mouths. And, the agriculture industry is accountable for fulfilling humans' need for food, energy, and shelter to a great extent. Also, there is one more distressing fact revealed by Bureau of labor statistics that employment of agricultural workers is projected to decline 3 percent from 2012 to 2022. And, what farmers would do to sustain the productivity, increase yield and feed additional 2.3 billion people by 2050. The only solution to all these problems is Agriculture Modernization that has already started by some of the tech savvy farmers. For the next generation agriculture fields, data collected from sensors would become the fertilizer to grow crops. It's really perplexing, but true. IOT would uncover the new ways that tap the full potential of agriculture yield and alleviate all the challenges that hinders the growth of the crop.

The term Internet of Things was first coined by Kevin Ashton in 1999 in the context of supply chain management [1]. The Internet of Things (IoT) is the "network of interconnected sensor-equipped electronic devices that collect data, communicate with each other, and can be monitored or controlled remotely over the Internet"[2]. The main goal of the IoT's development is extends the limit of internet connectivity from digital devices to physical objects. It enables the communication between digital devices, objects and other systems. The data collected can be shared between person to person, machines to person (M2P) or machine to machine (M2M)[3] and data is stored and managed at cloud. Looking to the future, it is predicted by Cisco IBSG that there will be 50 billion devices connected to the Internet by 2020.

The Smart Irrigation System is an IoT based device which is capable of automating the irrigation process by analyzing the moisture of soil and the climate condition (like raining). It provide water supply at the right time, in right quantity and at the right place in field which plays a vital role in the plant's growth. Water management remotely is also challenging task, especially the management becomes more difficult during the shortage of water, which may otherwise damage the crop. By using sensors like moisture, rain, etc. water supply for irrigation can be managed easily by analyzing the condition of soil and climate. Soil moisture sensors smartly measure the soil moisture and based on that data, field is get irrigated automatically with less human interventions. The complete data of moisture is accessible to the farmers at distance on the mobile in a graphical form.

II. SYSTEM ARCHITECTURE

The SIS consist of ATMEGA 328P microcontroller, which is brain of the system. A SOC called BOLT (IoT device) is used for communication between micro-controller and user through HTTP protocol. The user has to give one time command just to start the system and the rest of whole irrigation process will be controlled by the device automatically.

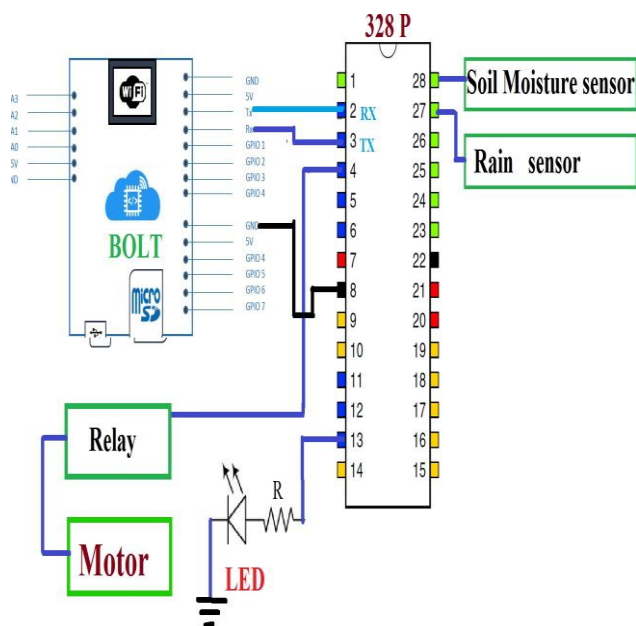

Fig 1- Block diagram of Device

III. COMPONENT DESCRIPTION

- ATMEGA 328P:-

The Atmel® Pico Power® ATmega328P is a low-power CMOS 8-bit microcontroller based on the AVR® enhanced RISC architecture. By executing powerful instructions in a single clock cycle, the ATmega328/P achieves throughputs close to 1MIPS per MHz. This empowers system designed to optimize the device for power consumption versus processing speed. All the 32 registers are directly connected to the Arithmetic Logic Unit (ALU), allowing two independent registers to be accessed in a single instruction executed in one clock cycle. The resulting architecture is more code efficient while achieving throughputs up to ten times faster than conventional CISC microcontrollers. It has Flash Memory of 32 KB, SRAM of 2 KB and EEPROM of 1 KB [4].

- Soil Moisture sensor:-

This sensor can be used to test the moisture of soil, when the soil is having water shortage, the module output is at high level, and else the output is at low level. By using this sensor one can automatically water the flower plant, or any other plants requiring automatic watering technique. Module triple output mode, digital output is simple, analog output more accurate, serial output with exact readings. It is also used in numerous research applications, e.g. in agricultural science and horticulture including irrigation planning, climate research, or environmental science including solute transport studies and as auxiliary sensors for soil respiration measurements [5].

- BOLT:-

BOLT is an Internet of Things platform (Hardware+ Software) that enables user to build IoT products and projects. It is developed by company name INVENTROM Pvt.Ltd. Using BOLT, users can control and monitor devices from any part of the world. It provides the ability to embed

Wi-Fi capabilities within other systems, or to function as a standalone application.

The manufacturers can embed the Bolt hardware in their product, develop a custom UI and then their users can control their products using the Net Plug app. Bolt works on pay as you go basis, which means the manufacturers have no capital investments to get their products IoT enabled. This lets even small scale players to build IoT enabled products and services [6].

- RELAY:-

A relay is an electrically operated switch. Many relays use an electromagnet to mechanically operate a switch, but other operating principles are also used, such as solid-state relays. Relays are used where it is necessary to control a circuit by a separate low-power signal, or where several circuits must be controlled by one signal. Relays are used wherever it is necessary to control a high power or high voltage circuit with a low power circuit, especially when galvanic isolation is desirable. Relays can work either as switches or as an amplifier (converting small currents into larger ones).

- ULN2003A:-

ULN2003A is an array of seven NPN Darlington transistors capable of 500 mA, 50 V output. It is known for its high-current, high-voltage capacity.

Application - Typical usage of the ULN2003A is in driver circuits for relays, lamp.

- Rain sensor:-

Rain sensor or rain switch is a switching device activated by rainfall. It is used water conservation device connected to an automatic irrigation system that causes the system to shut down in the event of rainfall.

IV. SOFTWARE DESIGN

The different software used in designing the complete system are –

- Arduino IDE:

This software is used to embed the c code in microcontroller. It is an open-source software that makes it easy to write the code and upload it to the board. It runs on Windows, Mac OS X, and Linux. A program written with the IDE for Arduino is called a sketch [7]. Sketches are saved on the development computer as text files with the file extension .ino.

- NOTEPAD++ :

Notepad++ is a text editor and source code editor for use with Microsoft Windows. It is one of the most popular source code editors in the world, and supports syntax highlighting and code folding for over 50 programming, scripting, and markup languages. It is used in my project for making the HTML page through which we are controlling the system manually [8].

➤ HTTP protocol :-

The Hypertext Transfer Protocol (HTTP) is an application protocol for distributed, collaborative, and hypermedia information systems [9]. HTTP is the foundation of data communication for the World Wide Web.

➤ API :-

In computer programming, an application programming interface (API) is a set of subroutine definitions, protocols, and tools for building application software. In general terms, it is a set of clearly defined methods of communication between various software components.

An API may be for a web-based system, operating system, database system, and hardware or software library. In context of web development, an API is typically defined as a set of Hypertext Transfer Protocol (HTTP) request messages, along with a definition of the structure of response messages, which is usually in an Extensible Markup Language (XML) or JavaScript Object Notation (JSON) format [10].

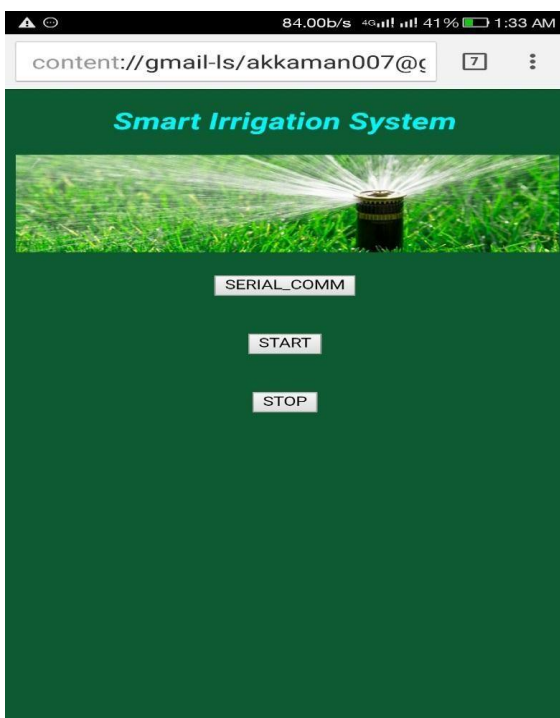

Fig 2- HTML page designed by NOTEPAD++

▪ DipTrace :

DipTrace is EDA/CAD software for creating schematic diagrams and printed circuit boards. The developers provide multi-lingual interface and tutorials (currently available in English and 21 other languages). DipTrace has 4 modules: Schematic Capture Editor, PCB Layout Editor with built-in shape-based autorouter and 3D Preview & Export, Component Editor, and Pattern Editor.

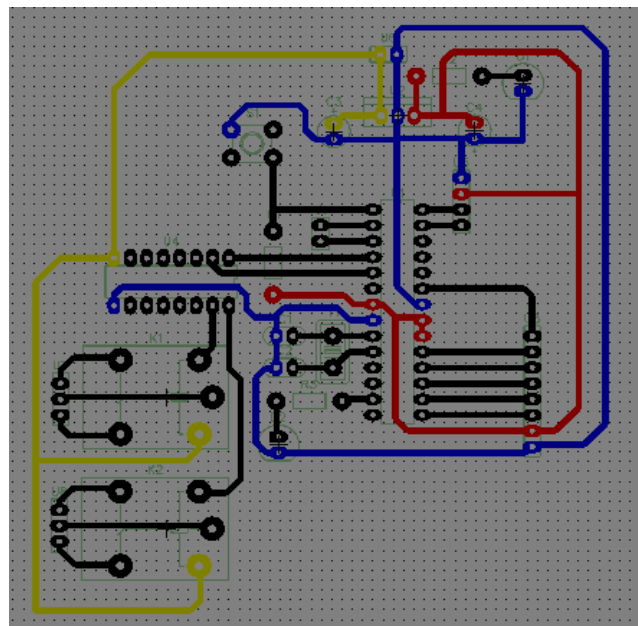

Fig 3- Circuit designing by DipTrace software

V. HARDWARE DESIGN

Process involved in making PCB of the system-

1. After drawing the circuit diagram of tested hardware on DipTrace software, we take out the print-out of the design on glossy paper.
2. Now, take a PCB board which is thin coated with copper and trace the print of glossy paper on board by using Iron Press.
3. Then, put the whole PCB board inside a ferrite solution for etching of remaining copper from PCB board.
4. Now, take a drilling machine for drilling the hole at right place according to circuit.
5. After that place all the electronics component at right place and solder it using soldering iron.

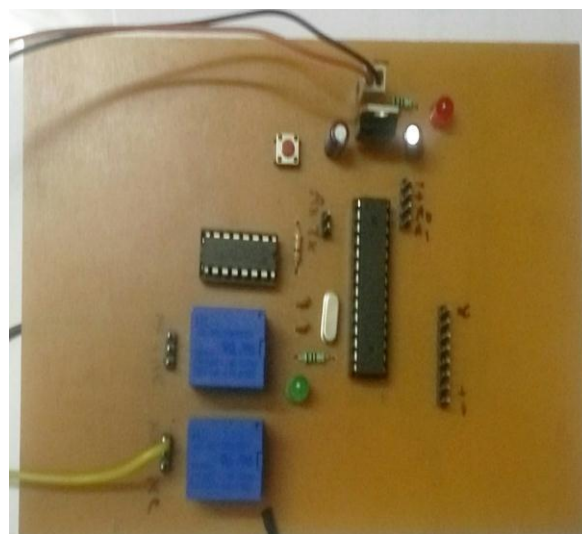

Fig3- Front end of designed PCB

VI. WORKING OF COMPLETE PROJECT

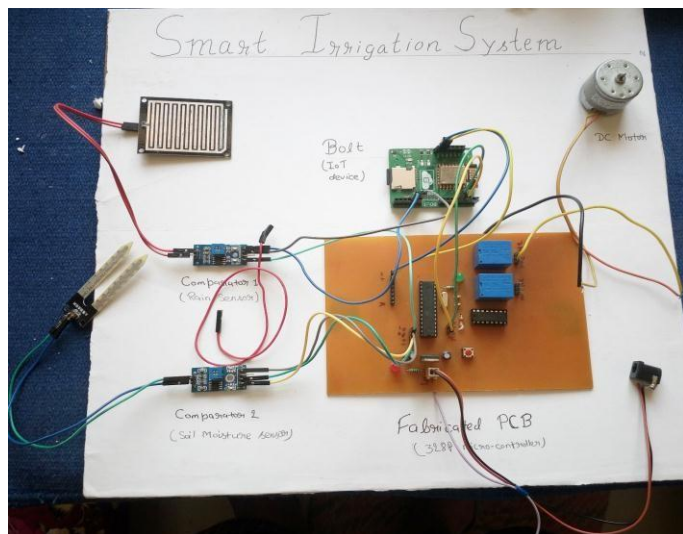

Fig 4- Complete working model of Smart Irrigation System

The working of system starts with sending a command by user by pressing a click button on web page to start the motor. This will sent a HTTP request, a string to Arduino through serial terminal which will match the string with the saved one in Arduino and if it is correct then it will start the motor.

After that the complete task of irrigating the field will be done by the microcontroller itself automatically. The microcontroller satisfy four different situations that may arise during the irrigation process:

1) Situation 1:

After starting the motor, the micro-controller will continuously read the sensors values (i.e. moisture and rain value) and also checks for HTTP request in order to stop the motor if user commands it according to his requirement. Through this the user has its control over the system.

2) Situation 2:

While reading the sensor value (i.e. moisture value) if it exceed the set threshold value then motor will stops automatically.

3) Situation 3:

This step is very important in water resource conservation. In case of climate condition such that it starts raining, the micro-controller will stop the motor temporarily till raining and after that it again check the moisture sensor value, if it doesn't exceeds set threshold value then motor will starts automatically (user has not start it by himself) but if sensor value exceeds the set threshold value then motor will stops permanently.

4) Situation 4:

Last, in case of power failure the motor will stop. But, when power supply will be reavailable then user has not to start the motor manually again, it will automatically get restarted because of programed EEPROM condition. This will provide less intervention of user.

VII. RESULT

The smart irrigation system was tested on a artificial small plot with all the above mentioned situation. The moisture value of soil moisture sensor is set to very low (i.e. 200) in IDE code of 328P microcontroller and it functioning properly. Also the condition of climate change is demonstrated well along with the power failure condition. In addition to this, the real time data of moisture sensor is displayed in graphical form on BOLT cloud page.

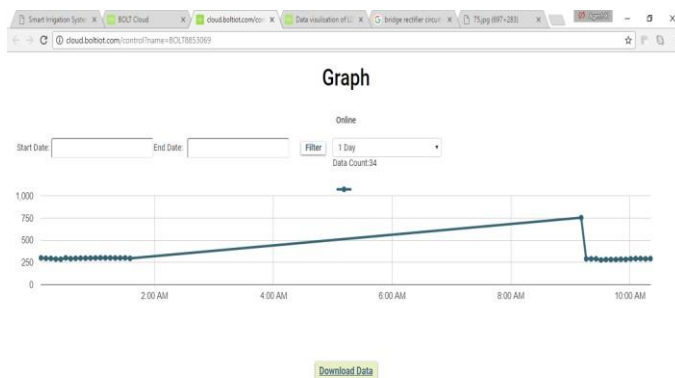

Fig 5- Real time data visualization of Soil Moisture sensor

	A	B	C	D	E
1	time_stamp	d_id	soil		
2	17-05-2017 18:35	8853069	300		
3	17-05-2017 18:40	8853069	295		
4	17-05-2017 18:45	8853069	294		
5	17-05-2017 18:50	8853069	288		
6	17-05-2017 18:55	8853069	286		
7	17-05-2017 19:00	8853069	300		
8	17-05-2017 19:05	8853069	292		
9	17-05-2017 19:10	8853069	295		
10	17-05-2017 19:15	8853069	297		
11	17-05-2017 19:20	8853069	297		
12	17-05-2017 19:25	8853069	298		
13	17-05-2017 19:30	8853069	299		
14	17-05-2017 19:35	8853069	301		
15	17-05-2017 19:40	8853069	301		
16	17-05-2017 19:45	8853069	300		

Fig 6- Datasheet of Soil Moisture sensor value

VIII. APPLICATION & FUTURE SCOPE

The SIS can not only used in field by the farmers but can be used to solve other problems where continuous monitoring of water supply is required like in a garden , or a personal small field ,or in the watering the stadium when necessary etc.

This project can be made further more innovative by adding - controlling and monitoring the sprinkles, checking the faults in the irrigation network and correcting them remotely and visualization the live working of integrated system in field area by pc/mobile. Also the future aspect of this model can be made into an intelligent system, wherein the system predicts user actions, rainfall pattern, time to harvest and many more features which will make the system independent of human operation. Systems can all be upgraded to Real Time systems, such that users receive real time updates and status of condition of the field. Thereby, enabling the user to take immediate action in case of any problems [11].

IX. CONCLUSION

The project concludes that automation of irrigation system will become easy and comfortable for farmers to operate the irrigation at remote location i.e. from home. This will save time and avoid problem of continuous vigilance. Not only this, it will also control the consumption of water for the irrigation of the field, thus preventing the water wastage and would help in sustain the productivity, increasing the yield.

X. REFERENCES

- [1] Stankovic, John. "Research directions for the internet of things." *Internet of Things Journal*, IEEE 1.1 (2014).
- [2] Ahrens, David. "Making Sense of The Internet of Things | STARS." *Making Sense of The Internet of Things | STARS*. N.p., 10 July 2014. Web. 28 Feb. 2015.
- [3] Michael Starsinic. *System Architecture Challenges in the Home M2M Network*. Applications and Technology Conference, 2010.
- [4] "Atmel 8-bit AVR Microcontrollers ATmega328/P Datasheet Summary" (PDF). June 2016. Retrieved 2016-07-14.
- [5] Decagon Devices "List of peer-reviewed publications using Decagon soil moisture sensors". Retrieved: 20 July 2015
- [6] <https://www.bolttiot.com>
- [7] "Programming Arduino Getting Started with Sketches". McGraw-Hill. Nov 8, 2011. Retrieved 2013-03-28.
- [8] DeCarlo, Matthew (2009-05-26). "Download of the Week: Notepad++". TechSpot. Retrieved 2009-10-01
- [9] Fielding, Roy T.; Gettys, James; Mogul, Jeffrey C.; Nielsen, Henrik Frystyk; Masinter, Larry; Leach, Paul J.; Berners-Lee, Tim (June 1999). *Hypertext Transfer Protocol – HTTP/1.1*. IETF. RFC 2616.
- [10] Benslimane, Djamel; Schahram Dustdar; Amit Sheth. "Services Mashups: The New Generation of Web Applications". *IEEE Internet Computing*, volume. 12, Number 5, (2008).
- [11] Yunseop (James) Kim, Member, IEEE, Robert G. Evans, and William M. Iversen, "Remote Sensing and Control of an Irrigation System Using a Distributed Wireless Sensor Network", *IEEE TRANSACTIONS ON INSTRUMENTATION AND MEASUREMENT*, Volume 57, Number 7, JULY 2008.