



Design of Controlled Car Engine System for Anti-Theft GSM and GPS Integrated SMS-

M.Ganesh¹, T.Bhavani², S.Naresh³, K.Srikanth⁴

^{1,2,3,4} Assistant Professor, Department of ECE, Sri Indu Institute of Engineering & Technology, Hyderabad

Abstract: *The latest trend of car theft involves the car being towed away, and also alarm signal capturing where the alarm disabler signal can be traced and duplicated by a thief with the device to capture the signal for disabling the alarm. There are many alternatives to prevent the car theft, common car alarm system which nearly all cars have the system installed. Steering, gear lock, tire lock and hidden “kill” switches which incapacitate fuel flow and many others. These GSM and GPS tracking system for cars project significantly reduce the time, manpower and operates without interference of humanoid. In the modern era, there are many new technologies like GPS, GSM, RFID and Biometric Recognition. Mobile communication which have been integrated with the vehicles for security purposes. In these projects GPS technology is used to find the exact location of the vehicle and GSM is used to send the message to the owner of the vehicle. If at a moment, the vehicle seems to be in theft, the owner can just send an SMS to that vehicle, which means that the vehicle will be stopped and all the doors will be closed then the thief will be locked in the car. The main intention of this project is to inform to the concerned authority through an SMS about the exact location of the stolen vehicle by theft. The system is aimed to locate the position of vehicle continuously, online data transmission method is implemented such that vehicle positions in the form of longitude & latitude values are monitored continuously through concern authorized mobile whenever the individual asks for its location. The demo model is constructed with two DC motors in which one is for the vehicle movement and the other for the door mechanism. Three keys are connected to the controller in which one is for vehicle start, one is for door opening and closing and the last for system reset. The entire control unit is designed using 89C52 controller to which the GSM, GPS and LCD are interfaced. The DC motors are driven through the relays by the controller.*

Keywords: SMS Based Car Engine Control System, Prevent Car Theft

1. Introduction

In India vehicle tracking system is mainly used in transportation industry that keeps a real - time tracking of all vehicles in the fleet. A vehicle tracking system combines the installation of an electronic device in a vehicle, or fleet of vehicles, with purpose designed computer software at least at one operational base enabling the owner or a third party to track the location of the vehicle, collecting data in the process from the field and deliver it to the operational base. The tracking system consists of GPS device that brings together GPS and GSM technology using tracking software. The GPS unit attached in the vehicles is programmed to send periodic messages about its locations to the route station through the server of the cellular network that can be displayed on a digitalized map via the Internet or specialized software. The location details are later transferred to users via SMS, e - mail or other form of data transfers. Public transport users are an increasingly users of vehicle tracking systems, particularly in large cities were GPS provides highly accurate information about the position and can be used for a variety of land, sea, and air applications. GPS, which began as a military application, has become a viable tool for many commercial and personal applications. One such application has been a vehicle location tracking system (VLTS). These tracking systems incorporate a GPS receiver and a wireless transceiver that allow a remote unit to track the vehicle's position. GPS Tracking device acquire GPS signals from GPS satellites and calculates its position on the earth. To acquire GPS information, a wireless receiver capable of the civilian L1 frequency (1575.42 MHz) is required. The GPS receiver measures distances to four or

more satellites simultaneously. Using triangulation the receiver can determine its latitude, longitude, and altitude. Google Earth Satellite Imagery for most of the cities (like top 20 cities) in India is available with very good resolution and one can see roads and buildings very clearly and identify them easily. New feature offered by Google called Google community inside Google Earth allow you to see place marks and names of various buildings, roads and key places in the city. Along with Google earth and Googlemaps, we have also provided the owners with various reports like Start - stop report which gives information about when the vehicle was started, where it stopped and for how much time approximately. Distance covered on a particular day. Day Begin - End report gives more details about the vehicle from early morning to late night. Detailed activity report gives detailed information about movements of the vehicle in a day. Other reports like Speed report; Fleet Summary report is also available. We also give customers access to detailed transaction history of the vehicle which can be exported to pdf or excel files for their further analysis. Customers can also use Google Earth to create list of land marks in the city like office, store, suppliers and customer locations where the vehicle is usually kept or visited by the owner. If these locations are marked in Google earth and place marks provided to our system, then in reports you can see, when did your vehicle reached these locations and how much time they were parked at these locations.

2. Functional Description

As the crime rate is increasing day by day, vehicle theft control system is essential for every vehicle. In this project if the user finds his/her vehicle stolen by sending a SM about

its location, can get the exact location of the vehicle to his mobile. And if necessary he can control the engine status i. e., switch it off by sending a message, by which the vehicle engine will be switched off, doors will be locked and the location data of the vehicle will be received to his mobile. This GSM based vehicle theft control system retrieves the exact location of vehicle in terms of its longitude and latitude through GPS. This data is used by the microcontroller system that is interconnected to a GSM modem. An SMS is sent to the concerned authority over GSM modem where the microcontroller reiterates the exact location details from the GPS and sends whenever the user asks for the vehicle location. An LCD screen display is connected to the microcontroller for cross checking the data received before being sent over the GSM to the server. This project will be very useful to people to keep track of their vehicles. Further this project is developed for making an arrangement to stop the ignition of the vehicle by the owner by sending an SMS in theft situations from remote places also. The vehicle owner when finds the vehicle is stolen. Then he can send back a SMS to the GSM modem to stop the engine. Here, GSM modem is interfaced to the 89C52 microcontroller that receives the message, the O/P of which activates mechanism that deactivates the ignition of the vehicle resulting in stopping the vehicle This project uses a DC motor to specify the ON/OFF condition of the vehicle. Therefore, the owner of the vehicle from anywhere can deactivate the engine o the vehicle. Further, this proposed system is developed by interfacing a GPS system which will give the exact location of the vehicle in terms of longitude and latitude further, this data can be sent to the vehicle owner Through an SMS who can enter this values on Google maps to get the vehicle location. The microcontroller and the GS modem are intercommunicated by MAX232 as an interface between them. The MAX232 acts as an interface between the GSM modem and the microcontroller to change the TTL the satellites. GPS TX pin is connected to microcontroller via switching transistor and GSM TX and RX pins are also connected to microcontroller via two more transistors Microcontroller does not check for RI interrupts of GSM, directly sends data to the predefined number with help of AT command set. Google Maps have been used to locate a vehicle for a program has been developed. It provides you a Live Tracking link for Google Earth o Google Maps. In case you have installed free software from Google called Google Earth on your computer, then just click on the Google Earth Live Tracking Link in your account and you can see the complete track of your vehicle for today along with fantastic Google earth satellite imagery. GSM is a Global system for mobile communication in this project acts as a SM Receiver and SMS transmitter with a baud rate 9600 bits/sec. Contains two kinds of power supply one is ac mode and another one is Battery mode. In the battery mode power is supplied to components like GSM, GPS and Microcontroller circuitry using a12/3.2A battery. GPS and GSM modules are given 12v dc as the modules circuit board are equipped with the regulators and derive the

required voltages for the components to be operating in the board and microcontroller requires 5v, which is derived with the help of 5v regulator. In the AC mode, a Step - down transformer is used to convert 230V AC to 12V, 1Amp AC and then goes to Bridge circuitry to convert that into DC signal. The signal is again passed through filter to get pureDC signal, which is then given t regulators and to the circuitry.

Hardware Details

- 1) ProGin SR - 87 GPS
- 2) GSM Module
- 3) AT89C52 Microcontroller
- 4) MAX232
- 5) LCD Display (2*16)
- 6) 7805 Voltage Regulator
- 7) Limit Switch

3. Block Diagram

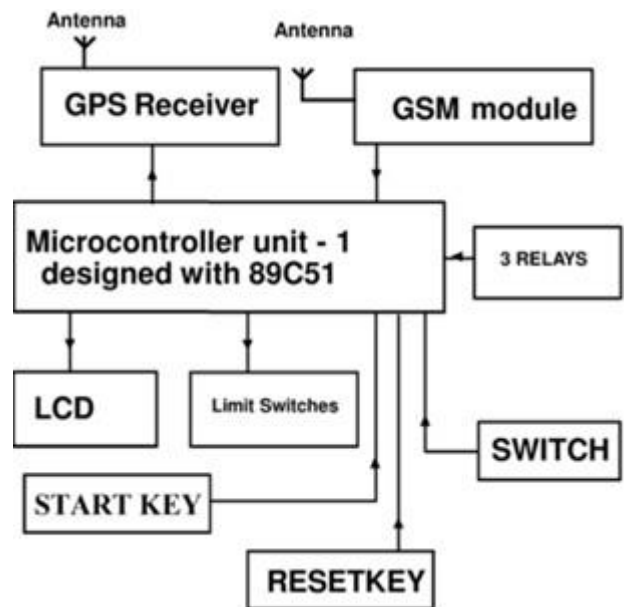

4. Conclusion

The Project titled “SMS based car engine control system using GSM & GPS” is a model for Vehicle Tracking unit with the help of Google maps and also with the help of GPS receivers and GSM modem. The positioning is done in the form of latitude and longitude along with the exact location of the place, by making use of Google maps. The system tracks the location of particular vehicle and sends to users mobile in the form of SMS whenever the user asks for the location. The arrived data, is in the form of latitude and longitude is used to locate the Vehicle on the Google maps and also we can see the output on the LCD as well as it will send the same data to the concerned mobile number. In addition the vehicle engine can be turned off by sending a SMS to the GSM modem in the vehicle.



References

- [1]http://google.about.com/od/mapsanddirections/fr/maps_rev.htm
- [2]Google MAPS API - <http://code.google.com/apis/maps/>
- [3]Microcontroller: www.8052.com
- [4]Michael j. point "EMBEDDED C" Pearson education limited 2002
- [5]Programming and Customizing the 8051 Micro - controller By: Myke Predko
- [6]The concepts and Features of Micro - controllers - By: Raj Kamal
- [7]The 8051 Micro - controller Architecture, programming & Applications By: Kenneth J. Ayala
- [8]Loren values - Latitude and Longitude conversion -
- [9]http://www.cosports.com/tools/gps_coords.htm
- [10]CMOS/TTL IC Data Manuals
- [11]Electronics for you Monthly Magazine
- [12]Practical Electronics Monthly Magazine
- [13]Elector India Monthly Magazine