



ESTD : 2007

Sri Indu Institute of Engineering and Technology (Autonomous)

(Formerly RVR Institute of Engineering & Technology)

An Autonomous Institution Under UGC

NAAC Accredited. Recognized Under 2(f) of UGC Act 1956

EAMCET CODE: INDI

Approved by AICTE, New Delhi, & Affiliated to JNTUH, Hyderabad.

JNTUH CODE: X3



COURSE FILE

ON

BASIC ELECTRICAL ENGINEERING

Course Code – EE201ES

**I B. Tech Semester-II
A.Y. 2022-2023**

**Prepared by
G.BHARGAVI
Asst. Professor**

Head of the Department
Department of H&S
SRI INDU INSTITUTE OF ENGG & TECH
Sheriguda (V), Ibrahimpatnam (M), R.R. Dist-501 510

PRINCIPAL
Sri Indu Institute of Engineering & Tech,
Sheriguda(VIII), Ibrahimpatnam
R.R. Dist. Telangana-501 510.



ESTD : 2007



Sri Indu Institute of Engineering and Technology (Autonomous)

(Formerly RVR Institute of Engineering & Technology)

An Autonomous Institution Under UGC

NAAC Accredited. Recognized Under 2(f) of UGC Act 1956

EAMCET CODE: INDI

Approved by AICTE, New Delhi, & Affiliated to JNTUH, Hyderabad.

JNTUH CODE: X3

Academic Year	2022-2023
Course Title	Basic Electrical Engineering
Course Code	EE201ES
Programme	B.Tech
Year & Semester	I & II
Branch & Section	AI&DS
Regulation	BR22
Course Faculty	G.BHARGAVI

Index of Course File

S. No.	Name of the content
1	Institute vision and mission
2	Programme outcomes
3	Course Syllabus with Structure
4	Course Outcomes (CO)
5	COs and POs Mapping and justification
6	Academic Calendar
7	Time table
8	Lesson plan
9	Web references & e-books
10	Lecture notes
11	PPTs
12	University Question papers
13	Internal Question papers, Key with CO and BT
14	Assignment Question papers mapped with CO and BT
15	Scheme of evaluation with CO and BT mapping
16	Result analysis
17	Remedial class time table
18	CO, PO attainment sheets.
19	Class register



ESTD : 2007



Sri Indu Institute of Engineering and Technology (Autonomous)

(Formerly RVR Institute of Engineering & Technology)

An Autonomous Institution Under UGC

NAAC Accredited. Recognized Under 2(f) of UGC Act 1956

EAMCET CODE: INDI

Approved by AICTE, New Delhi, & Affiliated to JNTUH, Hyderabad.

JNTUH CODE: X3

INSTITUTE VISION & MISSION

Vision:

To become a premier institute of academic excellence by providing the world class education that transforms individuals into high intellectuals, by evolving them as empathetic and responsible citizens through continuous improvement.

Mission:

- **IM1:** To offer outcome-based education and enhancement of technical and practical skills.
- **IM2:** To Continuous assess of teaching-learning process through institute-industry collaboration.
- **IM3:** To be a centre of excellence for innovative and emerging fields in technology development with state-of-art facilities to faculty and students' fraternity.
- **IM4:** To Create an enterprising environment to ensure culture, ethics and social responsibility among the stakeholders.

Head of the Department
Department of H&S
SRI INDU INSTITUTE OF ENGG & TECH
Sheriguda(VIII) Ibrahimpatnam (M) R.R. Dist-501 510

PRINCIPAL
Sri Indu Institute of Engineering & Tech.
Sheriguda(VIII), Ibrahimpatnam
R.R. Dist. Telangana-501 510.



SRI INDU INSTITUTE OF ENGINEERING AND TECHNOLOGY

(An Autonomous Institution under UGC)

Accredited by NAAC with A+ Grade, Recognized under 2(f) of UGC Act 1956

(Approved by AICTE, New Delhi and Affiliated to JNTUH, Hyderabad)

Khalsa Ibrahimpatnam, Sheriguda (V), Ibrahimpatnam (M), Ranga Reddy Dist., Telangana – 501 510

Website: <https://siiet.ac.in/>

PROGRAMME OUTCOMES

PO1: ENGINEERING KNOWLEDGE: Apply the knowledge of mathematics, science, engineering fundamentals, and an engineering specialization to the solution of complex engineering problems.

PO2: PROBLEM ANALYSIS: Identify, formulate, research literature, and analyze complex engineering problems reaching substantiated conclusions using first principles of mathematics, natural sciences, and engineering sciences.

PO3: DESIGN / DEVELOPMENT OF SOLUTIONS: Design solutions for complex engineering problems and design system components or processes that meet the specified needs with appropriate consideration for the public health and safety, and the cultural, societal, and environmental considerations.

PO4: CONDUCT INVESTIGATIONS OF COMPLEX PROBLEMS: Use research-based knowledge and research methods including design of experiments, analysis and interpretation of data, and synthesis of the information to provide valid conclusions.

PO5: MODERN TOOL USAGE: Create, select, and apply appropriate techniques, resources, and modern engineering and IT tools including prediction and modeling to complex engineering activities with an understanding of the limitations.

PO6: THE ENGINEER & SOCIETY: Apply reasoning informed by the contextual knowledge to assess societal, health, safety, legal and cultural issues and the consequent responsibilities relevant to the professional engineering practice.

PO7: ENVIRONMENT & SUSTAINABILITY: Understand the impact of the professional engineering solutions in societal and environmental contexts, and demonstrate the knowledge of, and need for sustainable development.

PO8: ETHICS: Apply ethical principles and commit to professional ethics and responsibilities and norms of the engineering practice.

PO9: INDIVIDUAL & TEAM WORK: Function effectively as an individual, and as a member or leader in diverse teams, and in multidisciplinary settings.

PO10: COMMUNICATION: Communicate effectively on complex engineering activities with the engineering community and with society at large, such as, being able to comprehend and write effective reports and design documentation, make effective presentations, give and receive clear instructions.

PO11: PROJECT MANAGEMENT & FINANCE: Demonstrate knowledge and understanding of the engineering and management principles and apply these to one's own work, as a member and leader in a team, to manage projects and in multidisciplinary environments.

PO12: LIFE-LONG LEARNING: Recognize the need for, and have the preparation and ability to engage in independent and life-long learning in the broadest context of technological change.

Head of the Department
Department of H&S
SRI INDU INSTITUTE OF ENGG & TECH
Sheriguda (V) Ibrahimpatnam (M) R.R. Dist-501 510



SRI INDU INSTITUTE OF ENGINEERING AND TECHNOLOGY

(An Autonomous Institution under UGC)

Accredited by NAAC with A+ Grade, Recognized under 2(f) of UGC Act 1956

(Approved by AICTE, New Delhi and Affiliated to JNTUH, Hyderabad)

Khalsa Ibrahimpatnam, Sheriguda (V), Ibrahimpatnam (M), Ranga Reddy Dist., Telangana – 501 510

Website: <https://siiet.ac.in/>

B.Tech. in ARTIFICIAL INTELLIGENCE AND DATA SCIENCE COURSE STRUCTURE, I YEAR SYLLABUS (BR22 Regulations) Applicable from Academic Year: 2022-23 Batch

I Year I Semester

S. No.	Course Code	Course Title	L	T	P	Credits
1.	MA101BS	Matrices and Calculus	3	1	0	4
2.	AP102BS	Applied Physics	3	1	0	4
3.	CS103ES	Programming for Problem Solving	3	0	0	3
4.	ME102ES	Engineering Workshop	0	1	3	2.5
5.	EN104HS	English for Skill Enhancement	2	0	0	2
6.	CS106ES	Elements of Computer Science & Engineering	0	0	2	1
7.	AP105BS	Applied Physics Laboratory	0	0	3	1.5
8.	CS107ES	Programming for Problem Solving Laboratory	0	0	2	1
9.	EN107HS	English Language and Communication Skills Laboratory	0	0	2	1
10.	*MC101ES	Environmental Science	3	0	0	0
11.		Induction Programme				
Total			14	3	12	20

I Year II Semester

S. No.	Course Code	Course Title	L	T	P	Credits
1.	MA201BS	Ordinary Differential Equations and Vector Calculus	3	1	0	4
2.	CH203BS	Engineering Chemistry	3	1	0	4
3.	ME201ES	Computer Aided Engineering Graphics	1	0	4	3
4.	EE201ES	Basic Electrical Engineering	2	0	0	2
5.	EC201ES	Electronic Devices and Circuits	2	0	0	2
6.	CH206BS	Engineering Chemistry Laboratory	0	0	2	1
7.	EE202ES	Basic Electrical Engineering Laboratory	0	0	2	1
8.	CS201ES	Python Programming Laboratory	0	1	2	2
9.	CS203ES	IT Workshop	0	0	2	1
Total			11	3	12	20



SRI INDU INSTITUTE OF ENGINEERING AND TECHNOLOGY

(An Autonomous Institution under UGC)

Accredited by NAAC with A+ Grade, Recognized under 2(f) of UGC Act 1956

(Approved by AICTE, New Delhi and Affiliated to JNTUH, Hyderabad)

Khalsa Ibrahimpatnam, Sheriguda (V), Ibrahimpatnam (M), Ranga Reddy Dist., Telangana – 501 510

Website: <https://siiet.ac.in/>

BASIC ELECTRICAL ENGINEERING

(Course Code: EE201ES)

(Common to ECE, CSE (AI&ML), CSE (IOT), AI&DS)

B.Tech. I Year II Sem.

L T P C

2 0 0 2

Prerequisites: Mathematics

Course Objectives:

- To understand DC and Single & Three phase AC circuits
- To study and understand the different types of DC, AC machines and Transformers.
- To import the knowledge of various electrical installations and the concept of power, power factor and its improvement.

Course Outcomes: After learning the contents of this paper the student must be able to

- Understand and analyze basic Electrical circuits
- Study the working principles of Electrical Machines and Transformers
- Introduce components of Low Voltage Electrical Installations.

UNIT-I:

D.C. Circuits: Electrical circuit elements (R, L and C), voltage and current sources, KVL&KCL, analysis of simple circuits with dc excitation. Superposition, Thevenin and Norton Theorems. Time-domain analysis of first-order RL and RC circuits.

UNIT-II:

A.C. Circuits: Representation of sinusoidal waveforms, peak and rms values, phasor representation, real power, reactive power, apparent power, power factor, Analysis of single-phase ac circuits consisting of R, L, C, RL, RC, RLC combinations (series and parallel), resonance in series R-L-C circuit. Three-phase balanced circuits, voltage and current relations in star and delta connections.

UNIT-III:

Transformers: Ideal and practical transformer, equivalent circuit, losses in



SRI INDU INSTITUTE OF ENGINEERING AND TECHNOLOGY

(An Autonomous Institution under UGC)

Accredited by NAAC with A+ Grade, Recognized under 2(f) of UGC Act 1956

(Approved by AICTE, New Delhi and Affiliated to JNTUH, Hyderabad)

Khalsa Ibrahimpatnam, Sheriguda (V), Ibrahimpatnam (M), Ranga Reddy Dist., Telangana – 501 510

Website: <https://siiet.ac.in/>

transformers, regulation and efficiency. Auto-transformer and three-phase transformer connections.

UNIT-IV:

Electrical Machines: Construction and working principle of dc machine, performance characteristics of dc shunt machine. Generation of rotating magnetic field, Construction and working of a three-phase induction motor, Significance of torque-slip characteristics. Single-phase induction motor, Construction and working. Construction and working of synchronous generator.

UNIT-V:

Electrical Installations: Components of LT Switchgear: Switch Fuse Unit (SFU), MCB, ELCB, MCCB, Types of Wires and Cables, Earthing. Types of Batteries, Important Characteristics for Batteries. Elementary calculations for energy consumption, power factor improvement and battery backup.

TEXT BOOKS:

1. D.P. Kothari and I. J. Nagrath, “Basic Electrical Engineering”, Tata McGraw Hill, 4th Edition, 2019.
2. MS Naidu and S Kamakshaiah, “Basic Electrical Engineering”, Tata McGraw Hill, 2nd Edition, 2008.

REFERENCE BOOKS:

1. P. Ramana, M. Suryakalavathi, G.T. Chandrasheker, “Basic Electrical Engineering”, S. Chand, 2nd Edition, 2019.
2. D. C. Kulshreshtha, “Basic Electrical Engineering”, McGraw Hill, 2009.
3. M. S. Sukhija, T. K. Nagsarkar, “Basic Electrical and Electronics Engineering”, Oxford, 1st Edition, 2012.
4. Abhijit Chakrabarthy, Sudipta Debnath, Chandan Kumar Chanda, “Basic Electrical Engineering”, 2nd Edition, McGraw Hill, 2021.
5. L. S. Bobrow, “Fundamentals of Electrical Engineering”, Oxford University Press, 2011.
6. E. Hughes, “Electrical and Electronics Technology”, Pearson, 2010.
7. V. D. Toro, “Electrical Engineering Fundamentals”, Prentice Hall India, 1989



SRI INDU INSTITUTE OF ENGINEERING AND TECHNOLOGY

(An Autonomous Institution under UGC)

Accredited by NAAC with A+ Grade, Recognized under 2(f) of UGC Act 1956

(Approved by AICTE, New Delhi and Affiliated to JNTUH, Hyderabad)

Khalsa Ibrahimpatnam, Sheriguda (V), Ibrahimpatnam (M), Ranga Reddy Dist., Telangana – 501 510

Website: <https://siiet.ac.in/>

COURSE OUTCOMES

Course Name: Basic Electrical Engineering (C124)

At the End of the course, student will be able to

CO No	DESCRIPTION
C124.1	Understanding basic concepts of electrical components, network analysis and transient analysis of DC circuits. (Understanding)
C124.2	Acknowledge of AC quantities, sinusoidal analysis of single phase and three phase circuits.(Understanding)
C124.3	Analysis of phasors for a single-phase transformer, recognize energy transfer in electromagnetic circuits, and calculate its efficiency (Analysis)
C124.4	Gains the knowledge about auto transformer and 3- transformer connections (Understanding)
C124.5	Study the working principles of Electrical Machines(Understanding)
C124.6	Application of different devices used in electrical installation (fuse, MCB, MCCB, ELCB, Earthing. etc) and power factor improvement. (Application)



SRI INDU INSTITUTE OF ENGINEERING AND TECHNOLOGY

(An Autonomous Institution under UGC)

Accredited by NAAC with A+ Grade, Recognized under 2(f) of UGC Act 1956

(Approved by AICTE, New Delhi and Affiliated to JNTUH, Hyderabad)

Khalsa Ibrahimpatnam, Sheriguda (V), Ibrahimpatnam (M), Ranga Reddy Dist., Telangana – 501 510

Website: <https://siiet.ac.in/>

COs and POs Mapping

Course outcome	PO 1	PO 2	PO 3	PO 4	PO 5	PO 6	PO 7	PO 8	PO 9	PO 10	PO 11	PO 12	PSO 1	PSO 2
C124.1	3	2	1	2	1	1	-	-	-	-	-	-	-	-
C124.2	3	3	1	-	-	-	-	-	-	-	-	-	-	-
C124.3	3	2	-	-	-	1	1	-	-	-	-	2	-	-
C124.4	3	1	-	-	-	-	-	-	-	-	-	2	-	-
C124.5	3	1	-	-	-	-	-	-	-	-	-	2	-	-
C124.6	3	-	-	-	-	2	-	-	-	-	-	2	-	-
PO Average	3	2	1	2	1	1	1					2		

CO PO MAPPING AND JUSTIFICATION

COURSE NAME: Basic Electrical Engineering (C124)

C124.1: Understanding basic concepts of electrical components, network analysis and transient analysis of DC circuits. (Understanding)

Mapped POs/PSOs: PO1, PO2, PO3, PO4, PO5, and PO6

PO	JUSTIFICATION/EXPLANATION
PO1	Gains knowledge on electrical engineering and network analysis
PO2	Reducing the complexity of the problems
PO3	Develop a solution by using mesh and nodal analysis
PO4	Student can solve the complicated network problems to simple network problems.
PO5	Develop a solution to complex circuit by using network theorems.
PO6	Apply reasoning informed by the contextual knowledge to assess societal, health, safety, legal and cultural issues

C124.2: Acknowledge of AC quantities, sinusoidal analysis of single phase and three phase circuits. (Understanding)

Mapped POs/PSOs: PO1, PO2 and PO3.

PO	JUSTIFICATION/EXPLANATION
PO1	Gains knowledge about AC quantities
PO2	Analysing the phasor representation
PO3	Developing the AC circuits with single basic network elements



SRI INDU INSTITUTE OF ENGINEERING AND TECHNOLOGY

(An Autonomous Institution under UGC)

Accredited by NAAC with A+ Grade, Recognized under 2(f) of UGC Act 1956

(Approved by AICTE, New Delhi and Affiliated to JNTUH, Hyderabad)

Khalsa Ibrahimpatnam, Sheriguda (V), Ibrahimpatnam (M), Ranga Reddy Dist., Telangana – 501 510

Website: <https://siiet.ac.in/>

C124.3: Analysis of phasors for a single-phase transformer, recognize energy transfer in electromagnetic circuits, and calculate its efficiency (Analysis)

Mapped POs/PSOs: PO1,PO2,PO6,PO7,PO12

PO	JUSTIFICATION/EXPLANATION
PO1	The device transformer is used to transfer electrical energy in electrical system
PO2	Gains knowledge on basic electrical circuits with which students can apply to real world electrical and electronics problems and applications
PO6	This device is used to reduce the wastage of power
PO7	It is lifelong usage with minimum loss
PO12	The device transformer placed in society for day to day usage

C124.4: Gains the knowledge about auto transformer and 3- transformer connections. (Understanding)

Mapped POs: PO1, PO2 and PO12.

PO	JUSTIFICATION/EXPLANATION
PO1	Gains the knowledge about regulation ,auto transformer and 3 phase transformer
PO2	Phasor analysis is used in determination of regulation
PO12	This devices has lifelong usage

C124.5: Study the working principles of Electrical Machines. (Understanding)

Mapped POs/PSOs: PO1, PO2 and PO12

PO	JUSTIFICATION/EXPLANATION
PO1	Gains the knowledge about electrical motors and generators
PO2	Determination of emf and torque with help of first principles of engineering sciences
PO12	This devices has lifelong usage

C124.6: Application of different devices used in electrical installation(fuse, MCB, MCCB, ELCB, Earthing.. etc) and power factor improvement. (Application)

Mapped POs: PO1, PO6 and PO12

PO	JUSTIFICATION/EXPLANATION
PO1	Gains knowledge about basic installation of electrical systems and power factor improvement
PO6	MCB, MCCB, ELCBs used for safety of electrical equipments.
PO12	It is lifelong usage.



SRI INDU INSTITUTE OF ENGINEERING AND TECHNOLOGY

(An Autonomous Institution under UGC)

Accredited by NAAC with A+ Grade, Recognized under 2(f) of UGC Act 1956

(Approved by AICTE, New Delhi and Affiliated to JNTUH, Hyderabad)

Khalsa Ibrahimpatnam, Sheriguda (V), Ibrahimpatnam (M), Ranga Reddy Dist., Telangana – 501 510

Website: <https://siiet.ac.in/>

Academic calendar



SRI INDU INSTITUTE OF ENGINEERING AND TECHNOLOGY

UGC Autonomous Institution, Accredited by NAAC with A+ Grade

Recognized under 2(f) of UGC Act 1956.

(Approved by AICTE, New Delhi and Affiliated to JNTUH, Hyderabad)

Khalsa Ibrahimpatnam, Sheriguda(V), Ibrahimpatnam(M), Ranga Reddy Dist., Telangana – 501 510

<https://siiet.ac.in/>

Lr. No. SIET/BR22/Academic Calendar/2022/02

Date: 15.12.2022

REVISED ACADEMIC CALENDAR I.B.TECH FOR THE ACADEMIC YEAR 2022-23 (BR22-REGULATIONS)

Dr. I. Satyanarayana,
Principal.

X3

To,
All the HOD's
Sir,

Sub: SIET (Autonomous)–Academic & Evaluation–Revised Academic Calendar for **I.B.Tech - I & II Semesters** for the academic year 2022-2023-Reg.

The approved Academic Calendar for **I.B.Tech – I & II Semesters** for the academic year 2022-23 is given below.

I-SEMESTER

S. NO	Description	Period		Duration
		From	To	
1.	Commencement of I Semester class work (including Induction programme)	03.11.2022		
2.	1 st Spell of Instructions	03.11.2022	28.12.2022	8 Weeks
3.	I Mid Examinations	29.12.2022	04.01.2023	1 Week
4.	Submission of First Mid Term Exam Marks to the Autonomous Section on or before	10.01.2023		
5.	2 nd Spell of Instructions	05.01.2023	02.03.2023	8 Weeks
6.	Second Mid Term Examinations	03.03.2023	09.03.2023	1 Week
7.	Preparation & Practical Examinations	10.03.2023	16.03.2023	1 Week
8.	Submission of Second Mid Term Exam Marks to the Autonomous Section on or before	16.03.2023		
9.	I Semester End Examinations	17.03.2023	01.04.2023	2 Weeks

II-SEMESTER

S. NO	Description	Period		Duration
		From	To	
1.	Commencement of II Semester class work	03.04.2023		
2.	1 st Spell of Instructions (including Summer Vacation)	03.04.2023	10.06.2023	10 Weeks
	Summer Vacation	15.05.2023	27.05.2023	2 Weeks
3.	I Mid Examinations	12.06.2023	17.06.2023	1 Week
4.	Submission of First Mid Term Exam Marks to the Autonomous Section on or before	23.06.2023		
5.	2 nd Spell of Instructions	19.06.2023	12.08.2023	8 Weeks
6.	II Mid Term Examinations	14.08.2023	19.08.2023	1 Week
7.	Preparation & Practical Examinations	21.08.2023	26.08.2023	1 Week
8.	Submission of Second Mid Term Exam Marks to the Autonomous Section on or before	26.08.2023		
9.	II Semester End Examinations	28.08.2023	09.09.2023	2 Weeks
Commencement of Class Work for II B.Tech I Semester – 11.09.2023				

Principal
Sri Indu Institute of Engineering and Technology
(An Autonomous Institution Under JNTUH)
Sheriguda (V), Ibrahimpatnam, R.R. Dist-501510.

Principal
Sri Indu Institute of Engineering and Technology
(An Autonomous Institution Under JNTUH)
Sheriguda (V), Ibrahimpatnam, R.R. Dist-501510.

Principal
Sri Indu Institute of Engineering and Technology
(An Autonomous Institution Under JNTUH)
Sheriguda (V), Ibrahimpatnam, R.R. Dist-501510.



SRI INDU INSTITUTE OF ENGINEERING AND TECHNOLOGY

(An Autonomous Institution under UGC)

Accredited by NAAC with A+ Grade, Recognized under 2(f) of UGC Act 1956.

(Approved by AICTE, New Delhi and Affiliated to JNTUH, Hyderabad)

KhalsaIbrahimpattam, Sheriguda(V), Ibrahimpattam(M), Ranga Reddy Dist., Telangana – 501 510

<https://siiet.ac.in/>

Class: AI &DS

Semester: II W.E.F-03-04-2023

LH:-D-210

	I 9:40- 10:30	II 10:30 - 11:20	III 11:20- 12:10	12:10- 12.45	IV 12.45- 1.35	V 1.35- 2.25	VI 2.25- 3.15	VII 3.15-4.00
MON	CAEG PRACTICE			L U N C H	EC	BEE	EDC	LIBRARY
TUE	EC/BEE LAB				ODE	EC	BEE	BEE(T)/EDC(T)
WED	ITWS LAB				ODE	EDC	BEE	PYTHON(T)
THU	ODE	EC	EDC		EC/BEE LAB			ODE(T)/EC(T)
FRI	BEE	ODE	ODE		CAEG PRACTICE			EDC(T)/BEE(T)
SAT	EDC	EC	BEE		PYTHON LAB			EC(T)/ODE(T)

Course Code	Course Name	Name of the Faculty	Course Code	Course Name	Name of the Faculty
MA201BS	ODE-Ordinary Differential Equations & Vector Calculus	V.SUJATHA	CH206BS	EC LAB-Engineering Chemistry Laboratory	K.MOUNIKA/V.MOUNIKA
CH203BS	EC-Engineering Chemistry	K.MOUNIKA	EE202ES	BEE LAB-Basic Electrical Engineering Laboratory	G.BHARGAVI/K.RAJASHEKAR
ME201ES	CAEG-Computer Aided Engineering Graphics	A.MALLESH	CS201ES	PYTHON Programming Laboratory	M.TEJASWI/ P.BALU
EE201ES	BEE-Basic Electrical Engineering	G.BHARGAVI	CS203ES	ITWS-IT Workshop	N.KEERTHI CHANDANA/B.SWATHI
EC201ES	EDC-Electronic Devices & Circuits	P.SRILATHA			

G. Srinivas
Class In-Charge

Ch. Saijith
Time Table Coordinator



[Signature]
Head of The Department
Sri Indu Institute of Engg. & Tech
Main Road, Sheriguda(V),
Ibrahimpattam(M), R.R. Dist.
Telangana 501 510



SRI INDU INSTITUTE OF ENGINEERING AND TECHNOLOGY

(An Autonomous Institution under UGC)

Accredited by NAAC with A+ Grade, Recognized under 2(f) of UGC Act 1956

(Approved by AICTE, New Delhi and Affiliated to JNTUH, Hyderabad)

Khalsa Ibrahimpatnam, Sheriguda (V), Ibrahimpatnam (M), Ranga Reddy Dist., Telangana – 501 510

Website: <https://siiet.ac.in/>

LESSON PLAN

S.NO	Unit	TOPIC	Number of Sessions Planned	Teaching method/Aids	Reference
1	I	Introduction -Basic circuit components, Ohms law, Kirchhoff's law-	1	Black Board	T1
2		Kirchhoff's current law, Kirchhoff's voltage law and problems	1	Black Board	T1
3		Basic definitions, types of elements, Types of sources	1	Black Board	R1
4		RLC series and parallel, Problems on RLC series and parallel	1	Black Board	T1
5		Node analysis, problems on node analysis	1	Black Board	T2
6		Mesh analysis, problems on mesh analysis	1	Black Board	T1
7		Star-delta and delta-star transformation	1	Black Board	R1
8		network theorems: Superposition	1	Black Board	T1
9		Thevenin's and Norton's theorem	1	Black Board	T2
10		Simple problems on theorems	2	Black Board	T1
11		Time domain analysis of RL and RC circuits	2	Black Board	T1
12	II	Introduction Basic definitions, Principle of AC voltage and waveforms	1	Black Board, PPT	T1
13		Average value, Root mean square value, Form factor and Peak factors of alternating currents and voltage	1	Black Board	R1
14		phasor representation of alternating quantities, J operator and phasor algebra	1	Black Board	T1
15		1- ϕ series circuit (RL,RC,RLC)	2	Black Board	T1
16		1- ϕ parallel circuit (RL,RC,RLC)	2	Black Board	T1,T2
17		series resonance in RLC circuit	2	Black Board	R1
18		three phase circuits	2	Black Board	T1



SRI INDU INSTITUTE OF ENGINEERING AND TECHNOLOGY

(An Autonomous Institution under UGC)

Accredited by NAAC with A+ Grade, Recognized under 2(f) of UGC Act 1956

(Approved by AICTE, New Delhi and Affiliated to JNTUH, Hyderabad)

Khalsa Ibrahimpatnam, Sheriguda (V), Ibrahimpatnam (M), Ranga Reddy Dist., Telangana – 501 510

Website: <https://siiet.ac.in/>

20	III	Principle & operation of transformer	1	Nptel video	W2,W4
21		Construction details of transformer	2	Nptel video	W2,W4
22		Ideal and Practical Transformer, Losses,	1	Black Board	T1
23		Efficiency of transformer, maximum efficiency condition, problems	2	Black Board	T2
24		Regulation of transformer, simple problems	2	Black Board	T1
25		auto transformer and 3 phase transformer connections	2	Black Board	T1
26	IV	Introduction to electrical machines, Generation of rotating magnetic fields	1	Black Board	T1
27		Construction and working of a three-phase induction motor	2	PPT,Black board	R1
28		Significance of torque-slip characteristic.	2	Black board	T1
29		Loss components and efficiency	1	Black board	T1,W3
30		slip and torque characteristics	2	Black board	T1
31		starting and speed control of induction motor	2	Black board	T2
32		Single-phase induction motor	1	Black board	T1
33		Construction of separately excited dc motor	1	Black board	T1
34		working & torque-speed characteristic of separately excited dc motor	2	Black board	R1
35		speed control of separately excited dc motor	1	Black board	T2
36	Construction and working of synchronous generators.	2	Black board	T1	
37	V	Electrical Installation:: switch fuse unit MCB,ELCB,MCCB	2	Black Board	T1
38		Types of wires, cables, Earthling.	2	Black Board	T1
39		Types of Batteries, important characteristics for batteries	2	Black Board	T1
40		Elementary calculations for energy consumption	2	Black Board	T1
41		Power factor improvement and battery backup.	2	Black Board	R1



SRI INDU INSTITUTE OF ENGINEERING AND TECHNOLOGY

(An Autonomous Institution under UGC)

Accredited by NAAC with A+ Grade, Recognized under 2(f) of UGC Act 1956

(Approved by AICTE, New Delhi and Affiliated to JNTUH, Hyderabad)

Khalsa Ibrahimpatnam, Sheriguda (V), Ibrahimpatnam (M), Ranga Reddy Dist., Telangana – 501 510

Website: <https://siiet.ac.in/>

TEXT BOOKS:

1. D.P. Kothari and I. J. Nagrath, “Basic Electrical Engineering”, Tata McGraw Hill, 4th Edition, 2019.
2. MS Naidu and S Kamakshaiah, “Basic Electrical Engineering”, Tata McGraw Hill, 2nd Edition, 2008.

REFERENCE BOOKS:

1. P. Ramana, M. Suryakalavathi, G.T. Chandrasheker, “Basic Electrical Engineering”, S. Chand, 2nd Edition, 2019.
2. D. C. Kulshreshtha, “Basic Electrical Engineering”, McGraw Hill, 2009.
3. M. S. Sukhija, T. K. Nagsarkar, “Basic Electrical and Electronics Engineering”, Oxford, 1st Edition, 2012.
4. Abhijit Chakrabarthi, Sudipta Debnath, Chandan Kumar Chanda, “Basic Electrical Engineering”, 2nd Edition, McGraw Hill, 2021.



SRI INDU INSTITUTE OF ENGINEERING AND TECHNOLOGY

(An Autonomous Institution under UGC)

Accredited by NAAC with A+ Grade, Recognized under 2(f) of UGC Act 1956

(Approved by AICTE, New Delhi and Affiliated to JNTUH, Hyderabad)

Khalsa Ibrahimpatnam, Sheriguda (V), Ibrahimpatnam (M), Ranga Reddy Dist., Telangana – 501 510

Website: <https://siiet.ac.in/>

WEB REFERENCES & E-BOOKS :

1	https://archive.nptel.ac.in/courses/108/104/108104139/
2	https://archive.nptel.ac.in/courses/108/102/108102146/
3	https://archive.nptel.ac.in/courses/108/105/108105053/
4	https://archive.nptel.ac.in/courses/108/108/108108076/
5	https://ocw.mit.edu/courses/6-002-circuits-and-electronics-spring-2007/resources/lecture-22/
6	https://www.electrical4u.com/
7	https://ocw.mit.edu/courses/6-01sc-introduction-to-electrical-engineering-and-computer-science-i-spring-2011/pages/unit-3-circuits/circuits/
8	https://www.youtube.com/watch?v=mq2zjmS8UMI
9	https://nptel.ac.in/courses/108105112
10	https://archive.nptel.ac.in/courses/108/105/108105112/
11	https://youtu.be/hRYEJNJNYsg?si=EaevkijP9karBbm7
12	https://youtu.be/YBJLaEqIjOI?si=wfQAW6pwmOHec6k2
13	https://youtu.be/c76CnTH8_y4?si=UtHhUNzWxxnHR-Y3



SRI INDU INSTITUTE OF ENGINEERING AND TECHNOLOGY

(An Autonomous Institution under UGC)

Accredited by NAAC with A+ Grade, Recognized under 2(f) of UGC Act 1956

(Approved by AICTE, New Delhi and Affiliated to JNTUH, Hyderabad)

Khalsa Ibrahimpatnam, Sheriguda (V), Ibrahimpatnam (M), Ranga Reddy Dist., Telangana – 501 510

Website: <https://siiet.ac.in/>

Lecture notes

Unit 1 link:

<https://drive.google.com/file/d/1OF6Ik2zVV7BST8h35eEbdLKBbYtmSvX1/view?usp=sharing>

Unit 2 link:

<https://drive.google.com/file/d/1PsvygXzVh9nMU1ul8CscxdCLB5ex9tKS/view?usp=sharing>

Unit 3 link: https://drive.google.com/file/d/16O-ukzS5_DdRY4_vquNX7qsgVxFBT2Oo/view?usp=sharing

Unit 4 link:

<https://drive.google.com/file/d/1BatVxO3gsXIuWEKjD--trkwsM9vckyw8/view?usp=sharing>

Unit 5 link:

<https://drive.google.com/file/d/1A7v58LXuprWBhGZUiDprQqbDiPKzAopU/view?usp=sharing>



SRI INDU INSTITUTE OF ENGINEERING AND TECHNOLOGY

(An Autonomous Institution under UGC)

Accredited by NAAC with A+ Grade, Recognized under 2(f) of UGC Act 1956

(Approved by AICTE, New Delhi and Affiliated to JNTUH, Hyderabad)

Khalsa Ibrahimpatnam, Sheriguda (V), Ibrahimpatnam (M), Ranga Reddy Dist., Telangana – 501 510

Website: <https://siiet.ac.in/>

List of PPTs

PPT-1 link:

<https://docs.google.com/presentation/d/10ZK2e36rOll6qAiVma0WkZGEjMxM46GK/edit#slide=id.p1>

PPT-2 link:

https://docs.google.com/presentation/d/1bQviA16dpExn8pe6m_rqRgDv74zNTCJO/edit#slide=id.p1

Course Code: EE201ES

BR22

SRI INDU INSTITUTE OF ENGINEERING AND TECHNOLOGY

UGC Autonomous Institution and Affiliated to JNTUH, Hyderabad

B.Tech I Year II Semester Examinations, August/ September -2023

X3

BASIC ELECTRICAL ENGINEERING

(Common to ECE, CSE (AI&ML), CSE(IOT), AI&DS)

Time: 3 Hours

Max. Marks: 60 Marks

Note: This question paper contains two parts A and B.

i) **Part- A** for 10 marks, ii) **Part - B** for 50 marks.

- Part-A is a compulsory question which consists of ten questions from all units carrying equal marks.
- Part-B consists of **ten questions** (numbered from 11 to 20) **carrying 10 marks each**. From each unit, there are two questions and the student should answer one of them. Hence, the student should answer five questions from Part-B.

PART-A

10x1=10Marks

1. Find the equivalent resistance when two resistors $R_1=100\Omega$ and $R_2=150\Omega$ connected in series?
2. State Ohm's Law ?
3. Define the peak value?
4. Define resonant frequency?
5. Define efficiency of a transformer?
6. Write the EMF equation of transformer.
7. What is back emf ?
8. Define slip?
9. Mention the Components of LT Switchgear?
10. State differences between wire and cable?

PART-B

5x10=50 Marks

- 11) Find the value of the current across 6 ohm resistor.?

[10]

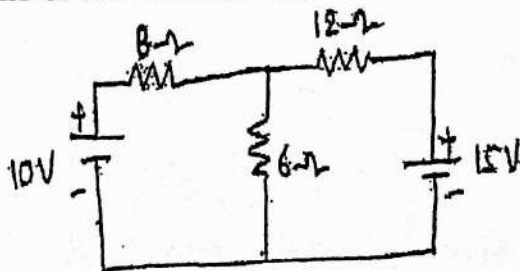

OR

- 12) Explain KVL & KCL by considering with suitable Examples.

[10]

13) Explain the Analysis of single-phase ac circuits consisting of RL, RC and RLC combinations? [10]

OR

14) A resistance of 300 ohms and inductance of 0.26 Henrys connected in series across a supply of 220V, 50Hz.

Determine

- i) Impedance
- ii) current
- iii) phase angle between current and voltage
- iv) power factor
- v) active power

[10]

15) Explain in detail about the different losses occurred in a transformer?

[10]

OR

16) Discuss the various three phase transformer connections?

[10]

17) Explain the constructional details of DC machine

[10]

OR

18) Explain the Construction and working of a three-phase induction motor. [10]

19) Explain MCB and MCCB with neat diagrams?

[10]

OR

20) What do you mean by power factor, explain its improvement methods? [10]

SRI INDU INSTITUTE OF ENGINEERING AND TECHNOLOGYUGC Autonomous Institution and Affiliated to JNTUH, Hyderabad
B.Tech I Year I Semester Examinations, August/ September -2023

X3

BASIC ELECTRICAL ENGINEERING

(Common to CSE, CSE (CS), CSE (DS))

Time: 3 Hours

Max. Marks: 60

Note: This question paper contains two parts A and B.i) **Part- A** for 10 marks, ii) **Part - B** for 50 marks.

- Part-A is a compulsory question which consists of ten questions from all units carrying equal marks.
- Part-B consists of **ten questions** (numbered from 11 to 20) **carrying 10 marks each**. From each unit, there are two questions and the student should answer one of them. Hence, the student should answer five questions from Part-B.

PART-A

10x1=10 Marks

1. State Kirchhoff's Current law?
2. Discuss resistor with relevant V-I expression
3. Define Power factor?
4. Define the Peak and RMS values.
5. Define voltage regulation of the transformer?
6. Write down emf equation of transformer?
7. Define synchronous speed.
8. What are the different types of motors?
9. What is ELCB?
10. What are Different types of Batteries?

PART-B

5x10=50 Marks

11. Explain Norton's theorem. With one example.

[10]

(or)

12. a) Explain about different types of circuit elements.

[5+5]

b) Calculate the Thevenin's equivalent resistance across load (6 ohms Resistance) terminal for the network shown in below

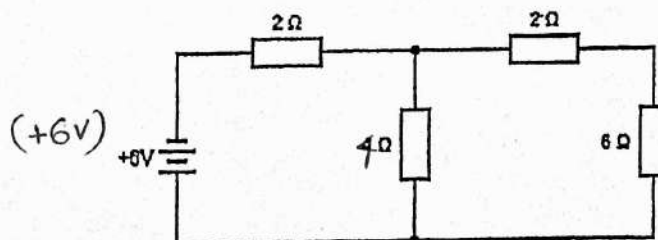

13. A series RLC circuit has $R = 15 \Omega$, $L = 100\text{mH}$ & $C = 29\mu\text{F}$. Calculate [10]
- i) the resonant frequency,
 - ii) the Q factor,
 - iii) Bandwidth of the circuit.
- (or)
14. A wound coil that has an inductance of 180mH and a resistance of 35Ω is connected to a 100V , 50Hz supply. Calculate [10]
- i) The impedance of the coil
 - ii) The current
 - iii) The power factor
 - iv) The apparent power consumed
 - v) the Real Power and Reactive Power consumed
15. Explain the principle and operation of single phase transformer? [10]
- (or)
16. a) Explain the operation of an auto transformer with a neat diagram.
b) What are the advantages of 3-phase Transformers? [5+5]
17. Explain the constructional details of DC machine [10]
- (or)
18. a) A 10-pole, 3-phase induction motor runs at a speed of 500 rpm at 50 Hz supply. Determine i) synchronous speed and ii) slip. [5+5]
b) Explain the principle of operation of 3phase induction Motor.
19. a) Explain the operation of ELCB with its schematic diagram.
b) Explain the operation of MCCB with its schematic diagram. [5+5]
- (or)
20. What do you mean by Earthing? Explain its types [10]

Course Code: EE101ES

BR22

SRI INDU INSTITUTE OF ENGINEERING AND TECHNOLOGY

UGC Autonomous Institution and Affiliated to JNTUH, Hyderabad

B .Tech I Year I Semester Regular Examinations, March-2023

X3

BASIC ELECTRICAL ENGINEERING

(Common to CSE, CSE (CS), CSE (DS))

Time: 3 Hours

Max. Marks: 60

Note: This question paper contains two parts A and B.
Part A is compulsory which carries 10 marks. All Questions Carry Equal Marks in Part A.
Part B consists of 5 Units. Answer any one full question from each unit.
Each question carries 10 marks and may have a, b, c as sub questions.

PART-A

10x1=10 Marks

1. Define current and voltage
2. State Kirchhoff's voltage law?
3. State Super position Theorem
4. What is meant by Reactive power?
5. Define transformer.
6. What is meant by equivalent resistance of single phase transformer referred to primary?
7. Define slip
8. What are the different types of generators?
9. List out the types of wires.
10. What are the different types of secondary Batteries?

PART-B

5x10=50 Marks

11. Explain superposition theorem with one example? [10]
(or)
12. Explain in detail the volt-ampere relationship of R, L and C elements with neat diagrams. [10]
13. A coil having a resistance of 10ohms and an inductance of 0.2H is connected in series with 100 μ F capacitor across a 230v, 50hz supply. find: [10]
 - i) impedance
 - ii) current
 - iii) Apprent Power, real power, reactive power.
 - iv) power factor.(or)
14. Define the following terms: [10]
 - i) Frequency
 - ii) Peak factor
 - iii) Form factor
 - iv) Peak value of an alternating quantity.
 - v) RMS value of an alternating quantity.

15. Explain single phase transformer on no load and full load conditions. [10]
(or)
16. a) Determine the condition for maximum efficiency in a single phase transformer.
b) What is a transformer? How does it transfer electrical energy from one circuit to another? [5+5]
17. a) Derive the torque equation of a DC motor.
b) Explain the constructional details of DC generator. [5+5]
(or)
18. Explain the working principle of synchronous generator. [10]
19. a) What is the difference between MCB and MCCB, describe their schematic diagrams?
b) What are the drawbacks of low power factor, describe how it is improved? [5+5]
(or)
20. What are the types of batteries? Explain [10]

Code No: 152AC

JAWAHARLAL NEHRU TECHNOLOGICAL UNIVERSITY HYDERABAD

B.Tech I Year II Semester Examinations, June - 2022

BASIC ELECTRICAL ENGINEERING

(Common to ECE, EIE, ECM, CSBS, CSE(AI&ML), CSE(IOT))

Time: 3 Hours

Max. Marks: 75

Answer any five questions
All questions carry equal marks

- - -

- 1.a) Two resistances when they are in series have an equivalent resistance of 9 ohms and when connected in parallel have an equivalent resistance of 2 ohms. Find the two resistances?
- b) State and explain Kirchoff's laws using an example. [7+8]
- 2.a) State and explain Thevenin's theorem.
- b) Find the current 'i' in the circuit below shown in figure using Norton's theorem. [7+8]

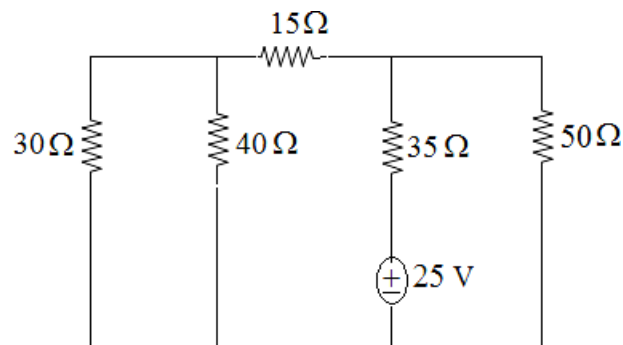

- 3.a) Explain about Series Resonance in a series RLC circuit and derive an expression for resonance frequency and quality factor.
- b) Each phase of a balanced three phase delta connected load has an impedance of $(4-j3) \Omega$. If a 3-phase voltage of 220 V supply is applied to this load, find the line and phase currents in the delta-connected load and the power delivered to the load. [7+8]
- 4.a) Define RMS value, Average value. Find Average value and RMS value of sinusoidal wave.
- b) A Resistor of 100Ω in series with a capacitance of $50\mu\text{F}$ is connected to a supply of 200V, 50Hz. Find: (i) impedance (ii) current (iii) phase angle (iv) voltage across resistance and capacitance. [7+8]
- 5.a) What is voltage regulation of a transformer and develop an expression for calculating the voltage regulation in the transformer.
- b) Calculate efficiency at half and full load of a 100 kVA transformer for power factor of (i) unity (ii) 0.8. The copper loss is 1000 W at full load and the iron loss is 1000 W. [8+7]
- 6.a) With neat constructional details, explain principle and operation of a synchronous generators.
- b) A 3-phase delta connected 440 V, 3-phase 50 Hz, 4-pole induction motor has a rotor standstill e.m.f per phase of 150 V. If the motor is running at 1450 rpm, determine for this speed (i) the slip (ii) the frequency of rotor induced e.m.f (iii) the rotor induced e.m.f per phase. [8+7]

- 7.a) Briefly describe the construction and principal of operation of single-phase induction motor.
- b) Describe briefly torque-slip characteristics of induction motor. Based on characteristics what are its applications? [8+7]
- 8.a) With the help of schematic diagram, explain the working principle of ELCB (Earth-Leakage Circuit Breaker). Discuss applications of ELCB.
- b) Write short note on Switch Fuse Unit (SFU). [10+5]

--ooOoo--

Code No: 151AG

JAWAHARLAL NEHRU TECHNOLOGICAL UNIVERSITY HYDERABAD

B.Tech I Year I Semester Examinations, June - 2022

BASIC ELECTRICAL ENGINEERING

(Common to EEE, CSE, IT, CSIT, ITE, CE(SE), CSE(CS), CSE(DS), CSE(Networks), CSED)

Time: 3 Hours

Max. Marks: 75

**Answer any five questions
All questions carry equal marks**

- - -

- 1.a) Explain in detail the passive elements and active elements.
 b) By using Thevenin's theorem shown in figure 1, find the current in 6Ω resistor. [8+7]

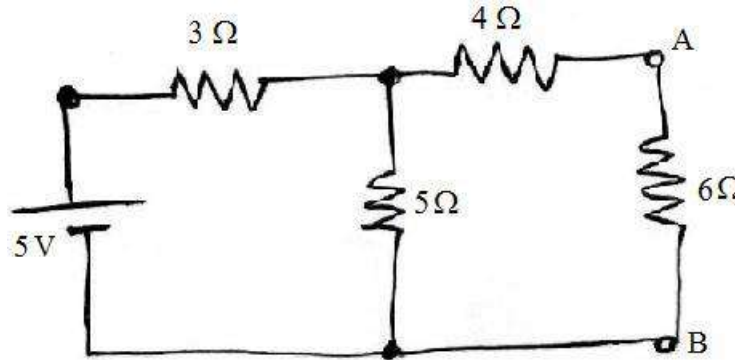

Figure 1

- 2.a) State Kirchhoff's voltage and current laws, Explain in detail.
 b) By using superposition theorem, find the current flowing through $2\ \text{ohms}$ resistor. (Figure 2) [8+7]

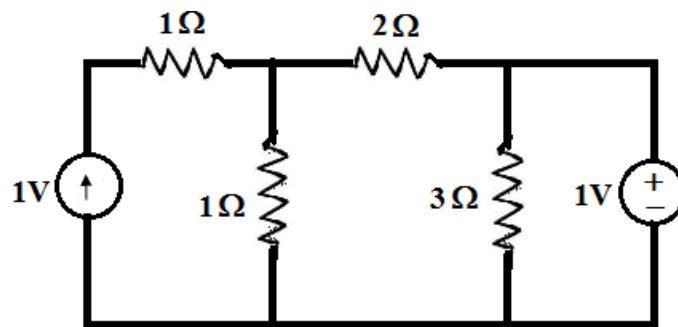

Figure 2

Explain the following terms of AC circuits

- | | | |
|-----------------|--------------------|-----------------------|
| (i) rms value | (ii) average value | (iii) peak value |
| (iv) formfactor | (v) phasor | (vi) phase difference |

- b) Analyze the series RL circuit with a neat sketch and also draw the phasor diagram. [8+7]

- 4.a) Derive the relation between phase voltage and line voltage of a balanced three phase star connected system.

- b) A circuit consisting of three branches, Z_2 is in parallel with Z_3 the combination is in series with Z_1 having the values $Z_1=5+j15$, $Z_2 =2.5+j5$ and $Z_3=2-j8$ connected across single phase, 100 V, 50 Hz supply. Find i) I_1 , I_2 and I_3 ii) V_1 and V_2 . [8+7]

The emf per turn of a 1- ϕ , 2200/220 V, 50 Hz transformer is approximately 12V.

Calculate

- i) The number of primary and secondary turns, and
 - ii) The net cross-sectional area of core for a maximum flux density of 1.5 T?
- b) Explain the losses in a Transformer; also derive the maximum efficiency condition of a transformer. [8+7]
- 6.a) Explain the significance of torque-slip and characteristics of 3-phase induction motor.
- b) Why three phase induction motor not rotating at synchronous speed, explain. [8+7]
- 7.a) Explain the types of batteries and its important characteristics.
- b) Define earthing also explain the purpose of earthing. [7+8]
- 8.a) Explain the constructional details of synchronous generators.
- b) Why single phase induction motors are not self starting motors? Explain. [7+8]

--ooOoo--

Code No: 152AC

JAWAHARLAL NEHRU TECHNOLOGICAL UNIVERSITY HYDERABAD

B.Tech I Year II Semester Examinations, September/October - 2021

BASIC ELECTRICAL ENGINEERING

(Common to ECE, EIE, ECM, CSBS, CSE(AI&ML), CSE(IOT))

Time: 3 Hours

Max. Marks: 75

Answer any five questions
All questions carry equal marks

- 1.a) Explain the V-I relation of circuit elements R, L and C.
 b) Find the value of current I_1 , I_2 and I_3 from the circuit given below figure 1. [6+9]

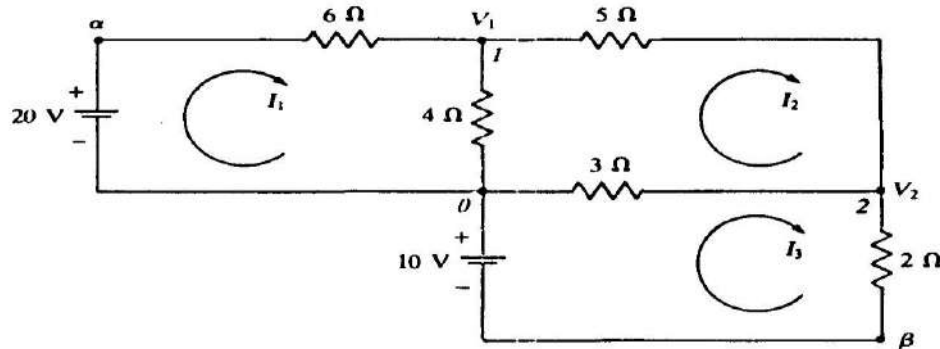

Figure: 1

- 2.a) Obtain an expression for transient current flowing through R-C series circuit excited by D.C source at $t=0^+$.
 b) Find the current flowing through 4 ohm resistance shown in figure 2 below using superposition theorem. [7+8]

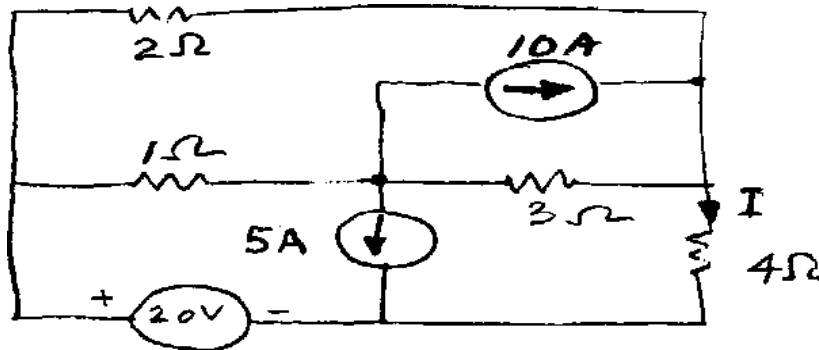

Figure: 2

- 3.a) Obtain an expression for active power in a single phase R-L circuit excited by sinusoidal voltage.
 b) Determine the power factor and the input power for a circuit with $v = 50 \sin(\omega t + 10^\circ)$ and $I = 2 \sin(\omega t + 20^\circ)$ A. [8+7]
- 4.a) A coil with inductance and resistance of 1 mH and 2 Ω respectively, is connected in series with a capacitor and this whole arrangement is connected across 120 V, 5 kHz A.C supply. Determine the value of capacitance that will cause the system to be in resonance.
 b) A star connected load has $5 \angle 30^\circ \Omega$ impedance per phase and is connected across 400 V three phase balanced source. Calculate the line current and the phase current. [8+7]

- 5.a) Give the applications of auto transformer.
- b) Calculate the values of R_0 , X_0 , R_{01} and X_{01} for the equivalent circuit of a single phase, 4 KVA, 200/400 V, 50 Hz transformer of which the following are the test results:
O.C. test: 200V, 0.7A, 70W
S.C. test: 15V, 10A, 80W [6+9]
- 6.a) State the advantages of 3-phase transformers.
- b) The iron and full load copper losses in a 80KVA single phase transformer are 500 and 1000W respectively. Calculate the efficiency at half full load, 0.8 p.f. lag. Find, also the load at which the efficiency is maximum? [6+9]
- 7.a) Explain why the rotor is forced to rotate in the direction of rotating magnetic field in a 3 phase Induction motor?
- b) A 3 phase, 50 Hz induction motor has a full load speed of 970 rpm. Calculate (i) number of the poles (ii) slip frequency. [9+6]
8. What is the need for earthing? Explain different types of earthing. [15]

---ooOoo---

SRI INDU INSTITUTE OF ENGINEERING AND TECHNOLOGY



UGC Autonomous Institution, Accredited by NAAC with A+ Grade

Recognized under 2(f) of UGC Act 1956.

(Approved by AICTE, New Delhi and Affiliated to JNTUH, Hyderabad)

Sheriguda(V), Ibrahimpatnam(M), R.R Dist., Telangana – 501 510

I B.Tech II SEM I - Mid Examinations, June-2023

X3

BR22

Set – II

Branch: ECE, CSE (AI&ML), CSE (IOT) & AI&DS

Date: 14-06-2023 (FN)

Subject: Basic Electrical Engineering

Marks: 20

Time: 2 Hours

Part-B

Answer any **FOUR** Questions. All Question Carry Equal Marks

4*5=20 Marks

1. In the circuit shown in below, Determine the current flowing through 5 ohms using Thevenin's theorem C124.1 Evaluating (L5)

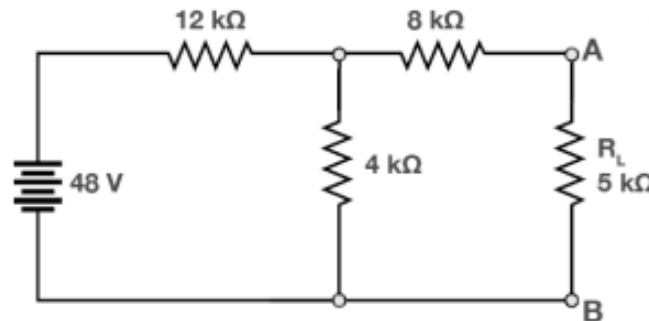

2. State and explain Norton's theorem. C124.1 understandingL2)
3. Derive the relation between line and phase quantities of voltage and current for a star connection and draw the phasor diagram. C124.2 Evaluating (L5)
4. A resistance of 10ohms and inductance of 0.1Henrys connected in series across a supply of 220V,50Hz.
Determine
i) Impedance
ii) current
iii) phase angle between current and voltage
iv) power factor
v) active power C124.2 Evaluating (L5)
5. Define the following terms: i) Cycle ii) Amplitude iii) R.M.S value and iv) Average value of an alternating quantity C124.2 Remembering (L1)
6. A 220/440 V single phase transformer has 1000 turns on primary. The maximum flux density in the core is 1.2 tesla. Calculate the number of turns on secondary, area of cross section and maximum flux in the core. C124.3 Evaluating (L5)

BT mapping

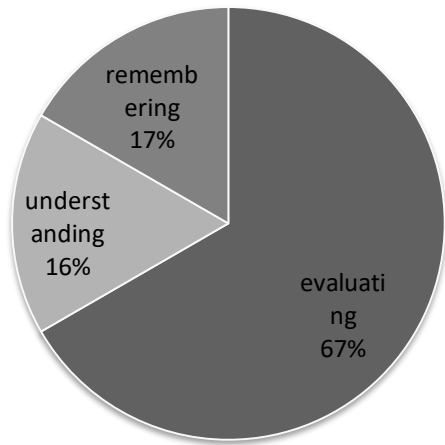

CO mapping

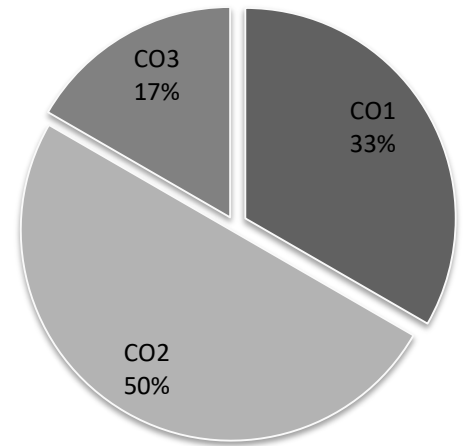

SRI INDU INSTITUTE OF ENGINEERING AND TECHNOLOGY



UGC Autonomous Institution, Accredited by NAAC with A+ Grade

Recognized under 2(f) of UGC Act 1956.

(Approved by AICTE, New Delhi and Affiliated to JNTUH, Hyderabad)

Sheriguda(V), Ibrahimpatnam(M), R.R Dist., Telangana – 501 510

I B.Tech II SEM I - Mid Examinations, June-2023

X3

BR22

Branch: ECE, CSE (AI&ML), CSE (IOT) & AI&DS

Date: 14-06-2023 (FN)

Subject: Basic Electrical Engineering

Marks: 10

Student Name: H.T.No.:

--	--	--	--	--	--	--	--	--	--

Part-A

Objective/Quiz Paper

The objective/quiz paper is set with multiple choice, fill-in the blanks and match the following type of questions for a total of 10 marks.

Multiple choices:

- Super position theorem is valid only for []
A. Linear circuits B. Both linear and non linear circuits
C. Non linear circuits D. Neither of the two
- Kirchhoff's current law is based on []
A. Law of conservation of energy B. Law of conservation of electric charge
C. Law of conservation of voltage D. Law of conservation of power
- Apparent power is expressed in []
A. Volt ampere B. Watts
C. Both A and B D. Volt Ampere Reactiv
- Electric power is transformed upon one coil to other coil in a transformer []
A. Electrically B. Electromagnetically
C. Magnetically D. Physically

Fill in the blanks:

- The no of mesh equations required for an electrical network with 'n' nodes is _____.
- The RMS value of a sine wave with peak value of 311 V is _____.
- If phase angle is 45° , the power factor is _____.
- Step up transformer is used to increase _____.

Match the following:

- | | | | |
|-----|---------------------|---------|-----------------------|
| i | active element | () | a. resistor |
| ii | passive element | () | b. transmission lines |
| iii | distributed element | () | c. diode |
| iv | unilateral element | () | d. battery |

SRI INDU INSTITUTE OF ENGINEERING AND TECHNOLOGY



UGC Autonomous Institution, Accredited by NAAC with A+ Grade

Recognized under 2(f) of UGC Act 1956.

(Approved by AICTE, New Delhi and Affiliated to JNTUH, Hyderabad)

Sheriguda(V), Ibrahimpatnam(M), R.R Dist., Telangana - 501 510

I B.Tech II SEM I - Mid Examinations, June-2023

X3

BR22

Answer key

Descriptive paper key link

<https://drive.google.com/file/d/1tGWL5pt030p3f1Qo-ndv-aDRBz7MblRN/view?usp=sharing>

Objective/Quiz Paper

Match the following:

1. A
2. B
3. B
4. B

Fill in the blanks:

5. n-1
6. 220v
7. 0.707
8. Voltage

Multiple choices:

9. I-D
- II-A
- III-B
- IV-C

Mid 1 answer script link:

<https://drive.google.com/file/d/1nDbL3M11HD9WvPhGs8OJ05aYSseugYjN/view?usp=sharing>

SRI INDU INSTITUTE OF ENGINEERING AND TECHNOLOGY



UGC Autonomous Institution, Accredited by NAAC with A+ Grade

Recognized under 2(f) of UGC Act 1956.

(Approved by AICTE, New Delhi and Affiliated to JNTUH, Hyderabad)

Sheriguda(V), Ibrahimpatnam(M), R.R Dist., Telangana – 501 510

I B.Tech II SEM II - Mid Examinations, August -2023

X3

BR22

Set – I

Branch: ECE, CSE (AI&ML), CSE (IOT) & AI&DS

Date: 17-08-2023 (FN)

Subject: Basic Electrical Engineering

Marks: 20

Time: 2 Hours

Part-B

Answer any **FOUR** Questions. All Question Carry Equal Marks

4*5=20 Marks

1. Derive the condition for maximum efficiency in a single phase transformer? C124.4 (Evaluation) (L4)
2. A three-phase induction motor runs at 1440 rpm at full load when supplied power from 50 Hz, 3-phase line.
Calculate
 - i. slip at full load
 - ii. frequency of rotor voltagespeed of rotor at a slip of 10% C124.5 (Evaluation) (L4)
3. Explain the constructional features of alternator? C124.5 (Understand)(L2)
4. Explain torque slip characteristics of 3 phase induction motor? C124.5 (Understand)(L2)
5. What is ELCB? Explain the working principle of ELCB? C124.6 (Remember)(L1)
6. Explain the working principle of MCB and MCCB with neat sketch? C124.6 (Remember)(L1)

BT mapping

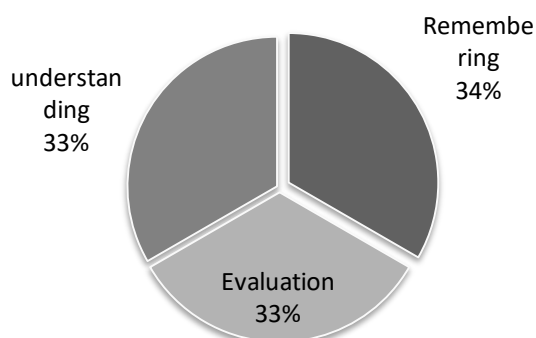

CO mapping

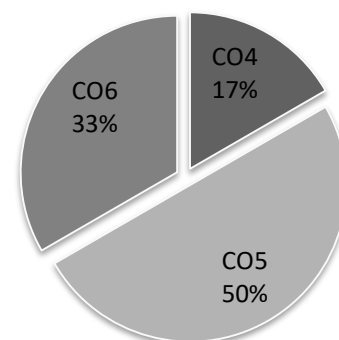

SRI INDU INSTITUTE OF ENGINEERING AND TECHNOLOGY



UGC Autonomous Institution, Accredited by NAAC with A+ Grade

Recognized under 2(f) of UGC Act 1956.

(Approved by AICTE, New Delhi and Affiliated to JNTUH, Hyderabad)

Sheriguda(V), Ibrahimpatnam(M), R.R Dist., Telangana – 501 510

I B.Tech II SEM II - Mid Examinations, August -2023

X3

BR22

Branch: ECE, CSE (AI&ML), CSE (IOT) & AI&DS

Date: 17-08-2023 (FN)

Subject: Basic Electrical Engineering

Marks: 10

Student Name: H.T.No.:

--	--	--	--	--	--	--	--	--	--

Part-A

Objective/Quiz Paper

The objective/quiz paper is set with multiple choice, fill-in the blanks and match the following type of questions for a total of 10 marks.

Multiple choices:

- Transformer core is laminated with []
a) Low carbon steel b) Silicon steel
c) Nickel alloy steel d) Chromium sheet steel
- An induction motor works with []
a) DC only b) AC only c) AC & DC d) pulsating DC
- In equipment grounding, the enclosure is connected to _____ wire []
a) Ground b) neutral c) both d) none
- The positive plate of lead acid cell is []
a) Nickel b) Iron c) Lead d) Zinc

Fill in the blanks:

- The basic function of a transformer is to change the level of _____ or _____.
- Synchronous speed $N_s =$ _____
- Slip rings are usually made of _____
- Pipe earthing used in _____ areas

Match the following:

- | | | |
|--------------------------------|-----|------------------|
| I. No of parallel paths $A=P$ | () | a) 0.5 to 5 ohms |
| II. No of parallel paths $A=2$ | () | b) Lap winding |
| III. Earth resistance | () | c) MCB |
| IV. Short circuit protection | () | d) Wave winding |

SRI INDU INSTITUTE OF ENGINEERING AND TECHNOLOGY



UGC Autonomous Institution, Accredited by NAAC with A+ Grade

Recognized under 2(f) of UGC Act 1956.

(Approved by AICTE, New Delhi and Affiliated to JNTUH, Hyderabad)

Sheriguda(V), Ibrahimpatnam(M), R.R Dist., Telangana – 501 510

I B.Tech II SEM II - Mid Examinations, August -2023

X3

BR22

ANSWER KEY

Descriptive paper key

https://drive.google.com/file/d/1lmhZxOrbLSTpzq0kv_fhZHpCPxObsI6x/view?usp=sharing

Objective/Quiz key Paper

Multiple choices:

1. B
2. B
3. A
4. c

Fill in the blanks:

5. voltage,current
6. 120f/p
7. Hard drawn copper
8. Domestic

Match the following:

9. I-b
II-D
III-A
IV-C

Mid 2 answer script link:

https://drive.google.com/file/d/1Wjvm1kdwOBXm5VOonZ_Tbyg5TmGq_5Im/view?usp=sharing



Assignment questions

Subject: Basic Electrical Engineering

1. In the circuit shown in below, Determine the current flowing through 5 ohms using Thevenin's theorem C124.1 Evaluating
(L5)

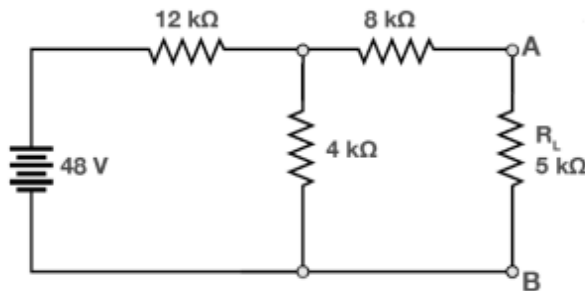

2. State and explain Norton's theorem. C124.1 understandingL2
3. In the circuit shown in below, Determine the current flowing through 5 ohms using Thevenin's theorem C124.1 Evaluating
(L5)

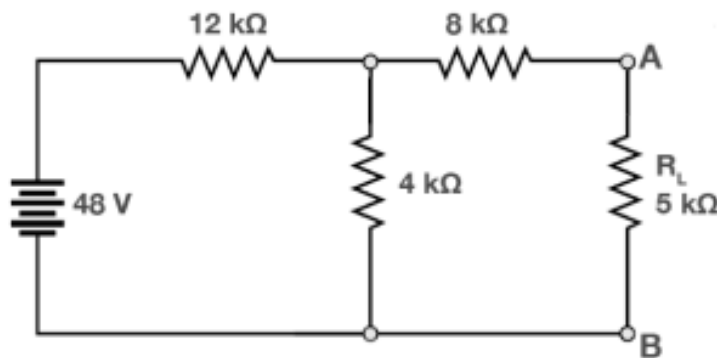

4. State and explain Norton's theorem. C124.1 Evaluating (L5)
5. Derive the relation between line and phase quantities of voltage and current for a star connection and draw the phasor diagram. C124.2 Evaluating (L5)
6. A resistance of 10ohms and inductance of 0.1Henrys connected in series across a supply of 220V,50Hz.
Determine
vi) Impedance
vii)current
viii) phase angle between current and voltage
ix) power factor
x) active power C124.2 Evaluating (L5)
7. Define the following terms: i) Cycle ii) Amplitude iii) R.M.S value and iv) Average value of an alternating quantity C124.2 Remembering (L1)

8. A 220/440 V single phase transformer has 1000 turns on primary. The maximum flux density in the core is 1.2 tesla. Calculate the number of turns on secondary, area of cross section and maximum flux in the core. C124.3 Evaluating (L5)
9. Derive the relation between line and phase quantities of voltage and current for a star connection and draw the phasor diagram. C124.2 Evaluating (L5)
10. A resistance of 10ohms and inductance of 0.1Henrys connected in series across a supply of 220V,50Hz.
Determine
xi) Impedance
xii) current
xiii) phase angle between current and voltage
xiv) power factor
xv) active power C124.2 Evaluating (L5)
11. Define the following terms: i) Cycle ii) Amplitude iii) R.M.S value and iv) Average value of an alternating quantity C124.2 Remembering (L1)
12. A 220/440 V single phase transformer has 1000 turns on primary. The maximum flux density in the core is 1.2 tesla. Calculate the number of turns on secondary, area of cross section and maximum flux in the core. C124.3 Evaluating (L5)

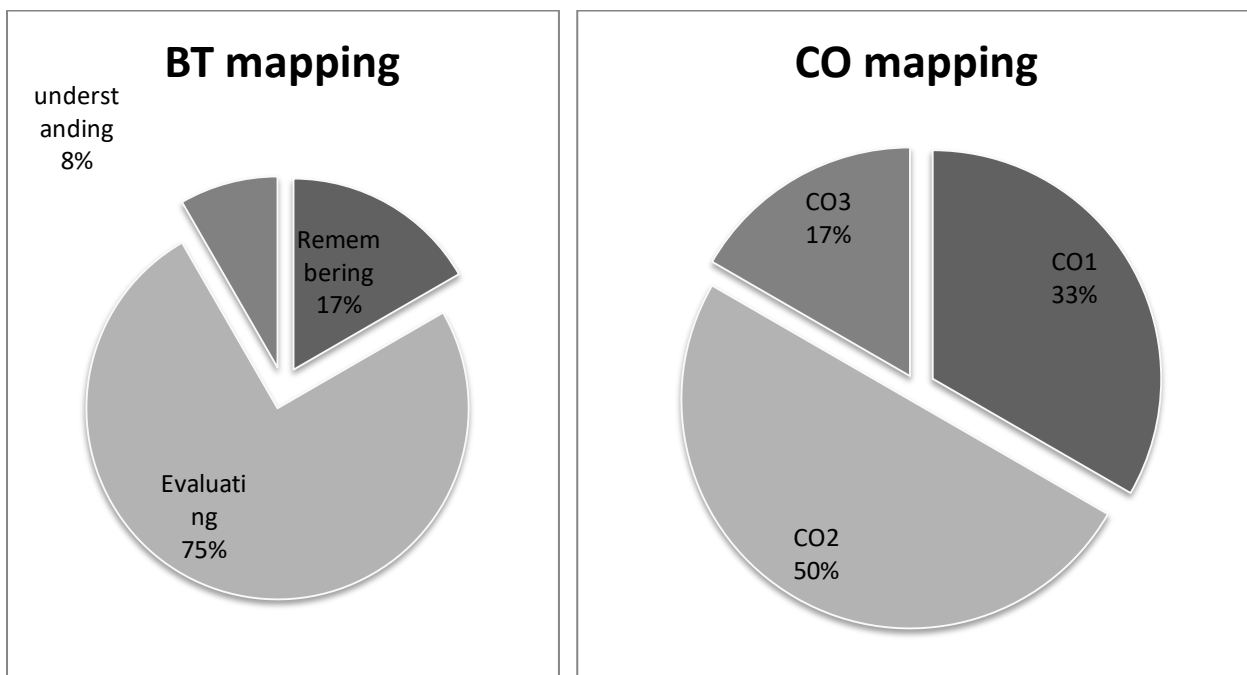

Mid 1 sample assignment link:

https://drive.google.com/file/d/1M1Liitsma2jG24S_b3veelk-jTQDfa_4/view?usp=sharing



ASSIGNMENT QUESTIONS

Subject: Basic Electrical Engineering

1. Derive the condition for maximum efficiency in a single phase transformer? C124.4 (Evaluation)
2. A three-phase induction motor runs at 1440 rpm at full load when supplied power from 50 Hz, 3-phase line.
Calculate
 - iii. slip at full load
 - iv. frequency of rotor voltagespeed of rotor at a slip of 10% C124.5 (Evaluation)
3. Explain the constructional features of alternator? C124.5 (Understand)
4. Explain about various losses of Single phase transformer? How to minimize them? C124.4 (Understand)
5. With neat sketches, explain the construction and functions of the various parts of a DC machine C124.5 (Understand)
6. Explain working of single phase induction motor with neat diagram? (Understand) C124.5
7. What are the different types of wires and cables? Explain? C124.6 (Remember)
8. Explain torque slip characteristics of 3 phase induction motor? C124.5 (Understand)
9. What is ELCB? Explain the working principle of ELCB? C124.6 (Remember)
10. Explain the working principle of MCB and MCCB with neat sketch? C124.6 (Remember)
11. With a neat sketch, explain earthing methods and give its applications? C124.6 (Remember)
12. Explain power factor improving methods? C124.6 (Remember)

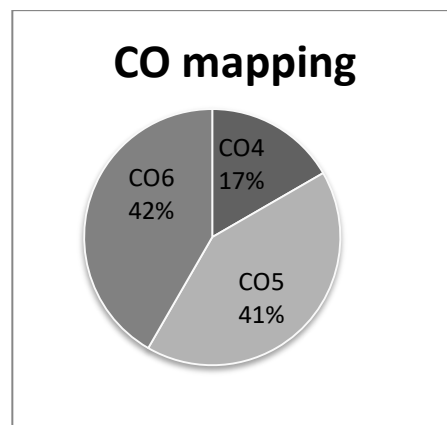
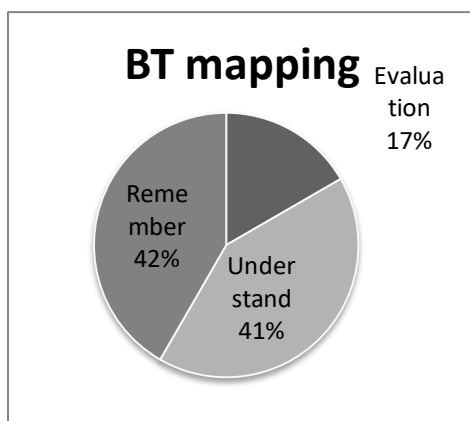

Mid 2 sample assignment link:

<https://drive.google.com/file/d/1bGIGHtDKaggp7kW9-M9j->

[Bnp7C1DtvQh/view?usp=sharing](https://drive.google.com/file/d/1bGIGHtDKaggp7kW9-M9j-Bnp7C1DtvQh/view?usp=sharing)



SRI INDU INSTITUTE OF ENGINEERING AND TECHNOLOGY

(An Autonomous Institution under UGC)

Accredited by NAAC with A+ Grade, Recognized under 2(f) of UGC Act 1956

(Approved by AICTE, New Delhi and Affiliated to JNTUH, Hyderabad)

Khalsa Ibrahimpatnam, Sheriguda (V), Ibrahimpatnam (M), Ranga Reddy Dist., Telangana – 501 510

Website: <https://siiet.ac.in/>

SCHEME OF EVALUATION

MID -I

S.NO	DESCRIPTION	MARKS	BLOOMS TAXONOMY	CO
1	Calculation of V_{th} ,	3	Evaluation(L4)	C124.1
	Calculation of R_{th} ,I	2	Evaluation(L4)	C124.1
2	Statement	1	Understanding(L2)	C124.1
	Explanation of Norton's theorem	4	Understanding(L2)	C124.1
3	Phasor diagram	3	Evaluation(L4)	C124.2
	Relation between line and phase quantities	2	Evaluation(L4)	C124.2
4	Calculation of impedance,current	2	Evaluation(L4)	C124.2
	Calculation of phase angle,power,power factor	3	Evaluation(L4)	C124.2
5	Defination of cycle,amplitude	1	Remembering (L1)	C124.2
	Determination of RMS value	2	Remembering (L1)	C124.2
	Determination of Average value	2	Remembering (L1)	C124.2
6	Calculation of turns N_1	1	Evaluation(L4)	C124.3
	Calculation of area	2	Evaluation(L4)	C124.3
	Calculation of maximum flux	2	Evaluation(L4)	C124.3



SRI INDU INSTITUTE OF ENGINEERING AND TECHNOLOGY

(An Autonomous Institution under UGC)

Accredited by NAAC with A+ Grade, Recognized under 2(f) of UGC Act 1956

(Approved by AICTE, New Delhi and Affiliated to JNTUH, Hyderabad)

Khalsa Ibrahimpatnam, Sheriguda (V), Ibrahimpatnam (M), Ranga Reddy Dist., Telangana – 501 510

Website: <https://siiet.ac.in/>

MID -II

S.NO	DESCRIPTION	MARKS	BLOOMS TAXONOMY	CO
1	Derivation of maximum efficiency	4	Evaluation(L4)	C124.4
	Condition of maximum efficiency	1	Evaluation (L4)	C124.4
2	Slip at full load	3	Evaluation (L4)	C124.5
	Frequency of rotor emf	2	Evaluation (L4)	C124.5
3	Constructional diagram of alternator	3	Understanding (L2)	C124.5
	Explanation of each part	2	Understanding (L2)	C124.5
4	Torque slip characteristics	2	Understanding (L2)	C124.5
	Explanation of each region	3	Understanding (L2)	C124.5
5	ELCB definition	1	Remembering (L1)	C124.6
	working principle of ELCB	4	Remembering (L1)	C124.6
6	Sketch of MCB	1	Remembering (L1)	C124.6
	Sketch of MCCB	1	Remembering(L1)	C124.6
	Working of MCB,MCCB	3	Remembering(L1)	C124.6



SRI INDU INSTITUTE OF ENGINEERING AND TECHNOLOGY

(An Autonomous Institution under UGC)

Accredited by NAAC with A+ Grade, Recognized under 2(f) of UGC Act 1956

(Approved by AICTE, New Delhi and Affiliated to JNTUH, Hyderabad)

Khalsa Ibrahimpatnam, Sheriguda (V), Ibrahimpatnam (M), Ranga Reddy Dist., Telangana – 501 510

Website: <https://siiet.ac.in/>

Branch : AI&DS

Subject: Basic Electrical Engineering

List of slow learners

S.No	Roll no	No of backlogs in I Sem	MID1 MARKS	MID2 MARKS
1	22X31A7214	3	18	19
2	22X31A7216	3	18	20
3	22X31A7230	3	17	18
4	22X31A7240	4	15	2
5	22X31A7263	3	20	16
6	22X31A7264	3	20	18

List of Advance learners

S.No	Roll no	Percentage in I Sem	MID1 MARKS	MID2 MARKS
1	22X31A7201	83.16	33	30
2	22X31A7203	83.26	24	26
3	22X31A7208	83.9	23	27
4	22X31A7226	89.3	33	32
5	22X31A7242	87.2	31	33
6	22X31A7249	86.1	32	28
7	22X31A7257	88.6	33	34
8	22X31A7259	87.2	33	33
9	22X31A7260	83.9	34	30



SRI INDU INSTITUTE OF ENGINEERING AND TECHNOLOGY

(An Autonomous Institution under UGC)

Accredited by NAAC with A+ Grade, Recognized under 2(f) of UGC Act 1956

(Approved by AICTE, New Delhi and Affiliated to JNTUH, Hyderabad)

Khalsa Ibrahimpatnam, Sheriguda (V), Ibrahimpatnam (M), Ranga Reddy Dist., Telangana – 501 510

Website: <https://siiet.ac.in/>

Branch : AI&DS

Subject: Basic Electrical Engineering

RESULT ANALYSIS

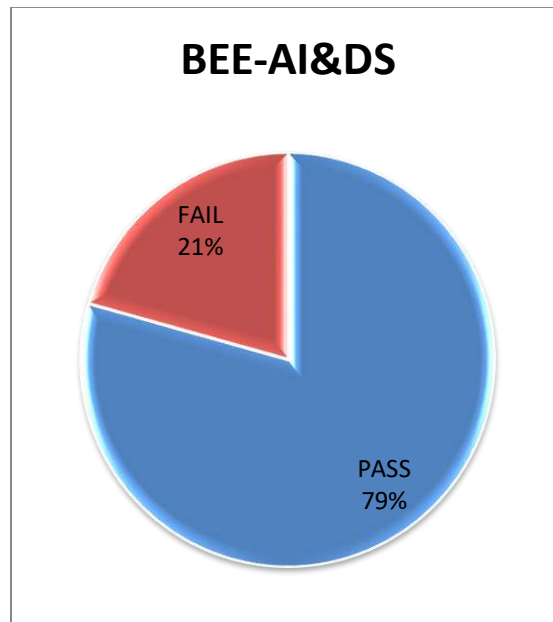
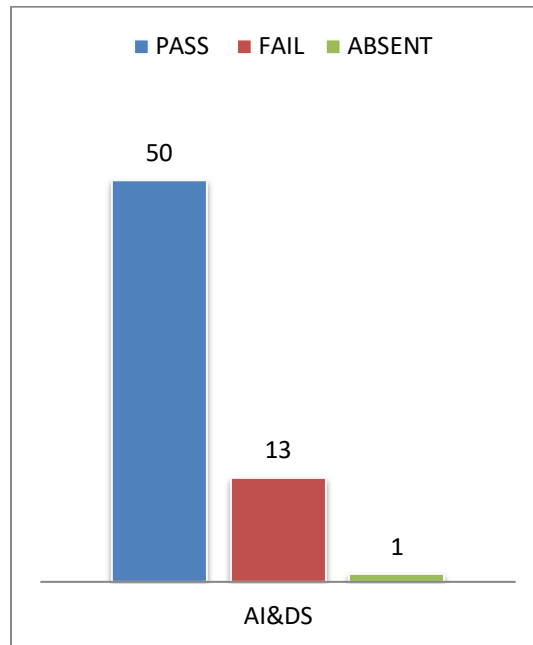



SRI INDU INSTITUTE OF ENGINEERING AND TECHNOLOGY

(An Autonomous Institution under UGC)

Accredited by NAAC with A+ Grade, Recognized under 2(f) of UGC Act 1956

(Approved by AICTE, New Delhi and Affiliated to JNTUH, Hyderabad)

Khalsa Ibrahimpatnam, Sheriguda (V), Ibrahimpatnam (M), Ranga Reddy Dist., Telangana – 501 510

Website: <https://siiet.ac.in/>

DEPARTMENT OF HUMANITIES AND SCIENCE REMEDIAL CLASSES TIME TABLE

DAY/ PERIOD	MON 4.00-5.00	TUE 4.00-5.00	WED 4.00-5.00	THUR 4.00-5.00	FRI 4.00-5.00	SAT 4.00-5.00
CSE-A	ODE&VC	ENG	EDC	AP	ODE&VC	AP
CSE-B	AP	EDC	ODE&VC	ENG	EDC	ENG
CSE-C	ENG	AP	EDC	ODE&VC	AP	ODE&VC

DAY/ PERIOD	MON 4.00-5.00	TUE 4.00-5.00	WED 4.00-5.00	THUR 4.00-5.00	FRI 4.00-5.00	SAT 4.00-5.00
DS	EDC	AP	ODE&VC	ENG	EDC	ODE&VC
CYBER	ENG	EDC	AP	ODE&VC	AP	ENG

DAY/ PERIOD	MON 4.00-5.00	TUE 4.00-5.00	WED 4.00-5.00	THUR 4.00-5.00	FRI 4.00-5.00	SAT 4.00-5.00
AIML-A	ODE&VC	EC	EDC	BEE	CAEG	ODE&VC
AIML-B	BEE	EDC	ODE&VC	EC	BEE	CAEG

DAY/ PERIOD	MON 4.00-5.00	TUE 4.00-5.00	WED 4.00-5.00	THUR 4.00-5.00	FRI 4.00-5.00	SAT 4.00-5.00
AI&DS	BEE	CAEG	ODE&VC	EDC	BEE	EC
IOT	EC	ODE&VC	CAEG	BEE	ODE&VC	EDC

DAY/ PERIOD	MON 4.00-5.00	TUE 4.00-5.00	WED 4.00-5.00	THUR 4.00-5.00	FRI 4.00-5.00	SAT 4.00-5.00
ECE	ODE&VC	BEE	EC	EDC	BEE	CAEG
CIVIL	ODE&VC	BEE	EC	AM	BEE	CAEG

Head of the Department
Department of H&S
SRI INDU INSTITUTE OF ENGG & TECH
Sheriguda (V) Ibrahimpatnam (M) R.R. Dist-501 510

PRINCIPAL
Sri Indu Institute of Engineering & Tech.
Sheriguda(VIII), Ibrahimpatnam
R.R. Dist. Telangana-501 510

52	22X31A7252	5			3								4			5			10	5	
53	22X31A7253	5			4								4			5			9	5	
54	22X31A7254	3			3					2						5			9	5	
55	22X31A7255	1			1					5						5			8	5	
56	22X31A7256	1			2								1			5			8	5	
57	22X31A7257	4								5			5			5			9	5	
58	22X31A7258	2			3								1			5			9	5	
59	22X31A7259	5			4								5			5			9	5	
60	22X31A7260				4					5			5			5			10	5	
61	22X31A7261	4			4					4						5			9	5	
62	22X31A7262	3			5											5			9	5	
63	22X31A7263				2								2			2			9	5	
64	22X31A7264				2			1		3									9	5	
Target set by the faculty / HoD		3.00	0.00	0.00	3.00	0.00	0.00	3.00	0.00	0.00	3.00	0.00	0.00	3.00	0.00	0.00	3.00	0.00	0.00	6.00	3.00
Number of students performed above the target		31	0	0	24	0	0	0	0	0	24	0	0	17	0	0	45	0	0	63	64
Number of students attempted		47	0	0	46	0	0	5	0	0	32	0	0	26	0	0	53	0	0	64	64
Percentage of students scored more than target		66%			52%			0%			75%			65%			85%			98%	100%

CO Mapping with Exam Questions:

CO - 1	Y			Y															Y	Y
CO - 2							Y			Y			Y						Y	Y
CO - 3																Y			y	y
CO - 4																				
CO - 5																				
CO - 6																				

>Target %	66%			52%			0%			75%			65%			85%			98%	100%
-----------	-----	--	--	-----	--	--	----	--	--	-----	--	--	-----	--	--	-----	--	--	-----	------

CO Attainment based on Exam Questions:

CO - 1	66%			52%															98%	100%
CO - 2							0%			75%			65%						98%	100%
CO - 3																85%			98%	100%
CO - 4																				
CO - 5																				
CO - 6																				

CO	Subj	obj	Asgn	Overall	Level
CO-1	59%	98%	100%	86%	3.00
CO-2	47%	98%	100%	82%	3.00
CO-3	85%	98%	100%	94%	3.00
CO-4					
CO-5					
CO-6					

Attainment Lev	
1	40%
2	50%
3	60%

Attainment (Internal 1 Examination) = **3.00**

SRI INDU INSTITUTE OF ENGINEERING AND TECHNOLOGY

Department of Humanities & Sciences

Course Outcome Attainment (Internal Examination-2)



Name of the faculty : G.BHARGAVI

Academic Year:

2022-2023

Branch & Section: AI&DS

Examination:

II Internal

Course Name: BASIC ELECTRICAL ENGINEERING

Year: I

Semester: II

S.No	HT No.	Q1a	Q1b	Q1c	Q2a	Q2b	Q2c	Q3a	Q3b	Q3c	Q4a	Q4b	Q4c	Q5a	Q5b	Q5c	Q6a	Q6b	Q6c	Obj	A2	viva/ ppt
Max. Marks ==>		5			5			5			5			5			5			10	5	5
1	22X31A7201	2			5						5			4						9	5	5
2	22X31A7202	4			1						4									9	4	5
3	22X31A7203	5			5						1						1			9	5	5
4	22X31A7204	3			3									3			2			8	5	5
5	22X31A7205				1									3			3			9	4	5
6	22X31A7206	2			1						2									8	4	5
7	22X31A7207				5															10	4	5
8	22X31A7208	5			5						2									10	5	5
9	22X31A7209				5									5			2			10	5	5
10	22X31A7210	5			5									1						10	5	5
11	22X31A7211				5												2			10	5	5
12	22X31A7212				5									1			1			10	4	5
13	22X31A7213				5						3			3						10	5	5
14	22X31A7214	2			2			2												10	3	5
15	22X31A7215	5			5									3			3			10	4	5
16	22X31A7216	1			4															10	5	5
17	22X31A7217	5			5															10	5	5
18	22X31A7218				5									1						10	5	5
19	22X31A7219	5			5															10	5	5
20	22X31A7220				5			2						1						10	5	5
21	22X31A7221							1			1			4			5			10	5	5
22	22X31A7222	5												2						10	5	5
23	22X31A7223				5			4						4			4			8	4	5
24	22X31A7224				5									4			1			9	5	5
25	22X31A7225				5						5			2			2			8	5	5
26	22X31A7226	5			5						3			5						9	5	5
27	22X31A7227	5			5			5						5						8	5	5
28	22X31A7228				5						2			1						9	4	5
29	22X31A7229				5						4			1			1			8	5	5
30	22X31A7230				2			2												10	4	5
31	22X31A7231	2			2			2			2									8	4	5
32	22X31A7232	2												2			2			8	4	5
33	22X31A7233	5			5						5			5						8	5	5
34	22X31A7234				5									4			2			9	4	5
35	22X31A7235				5			5			1			5						10	5	5
36	22X31A7236	5			5									1			5			8	4	5
37	22X31A7237	2			5			1						2						9	4	5
38	22X31A7238	1									2			2			2			10	5	5
39	22X31A7239				5						1			1						10	5	5
40	22X31A7240																				2	5
41	22X31A7241	5			5									2			2			6	5	5
42	22X31A7242	5			5						5						5			8	5	5
43	22X31A7243	4			5									4			3			6	4	5
44	22X31A7244	1			2									5			1			8	5	5
45	22X31A7245	5			5			4												9	5	5
46	22X31A7246	2			2			2												9	5	5
47	22X31A7247				5									3						9	2	5
48	22X31A7248	5			5			3												9	5	5
49	22X31A7249	5			5									5						8	5	5

50	22X31A7250	5			5															9	5	5	
51	22X31A7251									3										5	7	5	5
52	22X31A7252	3			5																8	5	5
53	22X31A7253	3			5			5													9	5	5
54	22X31A7254	2			2								2							2	8	5	5
55	22X31A7255	5											5							5	7	4	5
56	22X31A7256	3								5			4								8	4	5
57	22X31A7257	5			5								5							5	9	5	5
58	22X31A7258	5																			9	4	5
59	22X31A7259	5			5								5							5	9	4	5
60	22X31A7260	5			5					2			5								8	5	5
61	22X31A7261	2			5			3					2								8	5	5
62	22X31A7262	5			5																9	5	5
63	22X31A7263	2								2										2	6	4	5
64	22X31A7264	2			2																10	4	5
Target set by the faculty / HoD		3.00	0.00	0.00	3.00	0.00	0.00	3.00	0.00	0.00	3.00	0.00	0.00	3.00	0.00	0.00	3.00	0.00	0.00	6.00	3.00	3.00	
Number of students performed above the target		29	0	0	44	0	0	7	0	0	10	0	0	23	0	0	12	0	0	63	62	64	
Number of students attempted		43	0	0	54	0	0	14	0	0	21	0	0	39	0	0	27	0	0	63	64	64	
Percentage of students scored more than target		67%			81%			50%			48%			59%			44%			100%	97%	100%	

CO Mapping with Exam Questions:

CO - 1																							
CO - 2																							
CO - 3																							
CO - 4	Y																			Y	Y	y	
CO - 5			Y			Y			Y											Y	Y	y	
CO - 6												Y				y				Y	Y	y	

% Students Scored >Target %	67%			81%			50%			48%			59%			44%			100%	97%	100%
-----------------------------	-----	--	--	-----	--	--	-----	--	--	-----	--	--	-----	--	--	-----	--	--	------	-----	------

CO Attainment based on Exam Questions:

CO - 1																							
CO - 2																							
CO - 3																							
CO - 4	67%																			100%	97%	100%	
CO - 5				81%			50%			48%										100%	97%	100%	
CO - 6													59%			44%				100%	97%	100%	

CO	Subj	obj	aa	gn	ppt	Overall	Level
CO-1							
CO-2							
CO-3							
CO-4	67%	100%	97%	100%		91%	3.00
CO-5	60%	100%	97%	100%		89%	3.00
CO-6	52%	100%	97%	100%		87%	3.00

Attainment Level	
1	40%
2	50%
3	60%

Attainment (Internal Examination-2) = **3.00**



SRI INDU INSTITUTE OF ENGINEERING AND TECHNOLOGY

Department of Humanities & Sciences

Course Outcome Attainment (University Examinations)

Name of the faculty : G.BHARGAVI

Academic Year: 2022-2023

Branch & Section: AI&DS

Year / Semester: I / II

Course Name: BASIC ELECTRICAL ENGINEERING

S.No	Roll Number	Marks Secured
1	22X31A7201	33
2	22X31A7202	14
3	22X31A7203	33
4	22X31A7204	32
5	22X31A7205	36
6	22X31A7206	40
7	22X31A7207	40
8	22X31A7208	34
9	22X31A7209	42
10	22X31A7210	45
11	22X31A7211	26
12	22X31A7212	21
13	22X31A7213	39
14	22X31A7214	21
15	22X31A7215	45
16	22X31A7216	38
17	22X31A7217	44
18	22X31A7218	43
19	22X31A7219	41
20	22X31A7220	22
21	22X31A7221	31
22	22X31A7222	35
23	22X31A7223	30
24	22X31A7224	15
25	22X31A7225	22
26	22X31A7226	43
27	22X31A7227	29
28	22X31A7228	15
29	22X31A7229	17
30	22X31A7230	1
31	22X31A7231	16
32	22X31A7232	23
33	22X31A7233	45
34	22X31A7234	13
35	22X31A7235	29

S.No	Roll Number	Marks Secured
36	22X31A7236	33
37	22X31A7237	32
38	22X31A7238	15
39	22X31A7239	4
40	22X31A7240	0
41	22X31A7241	28
42	22X31A7242	32
43	22X31A7243	21
44	22X31A7244	26
45	22X31A7245	23
46	22X31A7246	9
47	22X31A7247	8
48	22X31A7248	37
49	22X31A7249	34
50	22X31A7250	24
51	22X31A7251	34
52	22X31A7252	21
53	22X31A7253	43
54	22X31A7254	23
55	22X31A7255	23
56	22X31A7256	28
57	22X31A7257	45
58	22X31A7258	27
59	22X31A7259	40
60	22X31A7260	38
61	22X31A7261	30
62	22X31A7262	36
63	22X31A7263	10
64	22X31A7264	7
65		
66		
67		
68		
69		
70		

Max Marks	60
Class Average mark	28
Number of students performed above the target	36
Number of successful students	64
Percentage of students scored more than target	56%
Attainment level	3

Attainment Level	% students
1	40%
2	50%
3	60%



SRI INDU INSTITUTE OF ENGINEERING AND TECHNOLOGY

Department of Humanities & Sciences

Course Outcome Attainment

Name of the faculty : G.BHARGAVI

Academic Year: 2022-2023

Branch & Section: AI&DS

Course Name: BASIC ELECTRICAL ENGINEERING

Year: I

Semester: II

Course Outcomes	1st Internal Exam	2nd Internal Exam	Internal Exam	University Exam	Attainment Level
CO1	3.00		3.00	3.00	3.00
CO2	3.00		3.00	3.00	3.00
CO3	3.00		3.00	3.00	3.00
CO4		3.00	3.00	3.00	3.00
CO5		3.00	3.00	3.00	3.00
CO6		3.00	3.00	3.00	3.00
Internal & University Attainment:			3.00	3.00	
Weightage			40%	60%	
CO Attainment for the course (Internal, University)			1.20	1.80	
CO Attainment for the course (Direct Method)			3.00		

Overall course attainment level

3.00



SRI INDU INSTITUTE OF ENGINEERING & TECHNOLOGY

Department of Humanities & Sciences

Program Outcome Attainment (from Course)

Name of Faculty: G.BHARGAVI Academic Year: 2022-2023
 Branch & Section: AI&DS Year: I
 Course Name: BASIC ELECTRICAL ENGINEERING Semester: II

CO-PO mapping

	PO1	PO2	PO3	PO4	PO5	PO6	PO7	PO8	PO9	PO10	PO11	PO12	PSO1	PSO2
CO1	3	2	1	2	1	1	-	-	-	-	-	-	-	-
CO2	3	3	1	-	-	-	-	-	-	-	-	-	-	-
CO3	3	2	-	-	-	1	1	-	-	-	-	2	-	-
CO4	3	1	-	-	-	-	-	-	-	-	-	2	-	-
CO5	3	1	-	-	-	-	-	-	-	-	-	2	-	-
CO6	3	-	-	-	-	2	-	-	-	-	-	2	-	-
Course	3.00	1.80	1.00	2.00	1.00	1.33	1.00					2.00		

CO	Course Outcome Attainment
CO1	3.00
CO2	3.00
CO3	3.00
CO4	3.00
CO5	3.00
CO6	3.00
Overall course attainment level	3.00

PO-ATTAINMENT

	PO1	PO2	PO3	PO4	PO5	PO6	PO7	PO8	PO9	PO10	PO11	PO12
CO Attainment	3.00	1.80	1.00	2.00	1.00	1.33	1.00					2.00

CO contribution to PO - 33%, 67%, 100% (Level 1/2/3)



SRI INDU INSTITUTE OF ENGINEERING AND TECHNOLOGY

(An Autonomous Institution under UGC)

Accredited by NAAC with A+ Grade, Recognized under 2(f) of UGC Act 1956

(Approved by AICTE, New Delhi and Affiliated to JNTUH, Hyderabad)

Khalsa Ibrahimpatnam, Sheriguda (V), Ibrahimpatnam (M), Ranga Reddy Dist., Telangana – 501 510

Website: <https://siiet.ac.in/>

Class register link:

<https://drive.google.com/file/d/1WiAHJU9znlk2lIO6O8bvXWECiVB1hAi/view?usp=sharing>